



A Deliverable by the NGMN Alliance

RAN EVOLUTION PROJECT

COMP EVALUATION AND ENHANCEMENT

next generation mobile networks



RAN EVOLUTION PROJECT

CoMP EVALUATION AND ENHANCEMENT

BY NGMN ALLIANCE

DATE: 31-MARCH-2015

VERSION 2.0

For all Confidential documents (CN, CL, CR):

This document contains information that is confidential and proprietary to NGMN Ltd. The information may not be used, disclosed or reproduced without the prior written authorisation of NGMN Ltd., and those so authorised may only use this information for the purpose consistent with the authorisation.

For Public documents (P):

© 2015 Next Generation Mobile Networks Ltd. All rights reserved. No part of this document may be reproduced or transmitted in any form or by any means without prior written permission from NGMN Ltd.

The information contained in this document represents the current view held by NGMN Ltd. on the issues discussed as of the date of publication. This document is provided "as is" with no warranties whatsoever including any warranty of merchantability, non-infringement, or fitness for any particular purpose. All liability (including liability for infringement of any property rights) relating to the use of information in this document is disclaimed. No license, express or implied, to any intellectual property rights are granted herein. This document is distributed for informational purposes only and is subject to change without notice. Readers should not design products based on this document.

Commercial Address:

ngmn Ltd.,

Großer Hasenpfad 30 • 60598 Frankfurt • Germany

Phone +49 69/9 07 49 98-04 • Fax +49 69/9 07 49 98-41

Registered Office:

ngmn Ltd.,

Reading Bridge House • George Street • Reading •
Berkshire RG1 8LS • UK

Company registered in England and Wales n. 5932387,
VAT Number: GB 918713901



CONFIDENTIALITY CLASS	P-PUBLIC
PROJECT	CoMP WORK STREAM, RAN EVOLUTION PROJECT
EDITOR IN CHARGE	LIFENG HE, QIXING WANG
EDITING TEAM	CMCC, DT, ALU, SAMSUNG, VODAFONE, ORANGE, ZTE, NSN, ERICSSON, TELEFONICA
DOCUMENT TYPE	FINAL DELIVERABLE (APPROVED)
APPROVED BY	APPROVED BY NGMN BOARD

Abstract: In existing commercial and trial LTE networks, testing results show that the inter-cell interference is very severe. CoMP is an important feature to cope with the inter-cell interference from operators' point of view. In this white paper, CoMP field trial testing results are shared and different enhanced CoMP schemes are compared. Moreover, a recommendation and a guideline from operators' point of view are required to drive 3GPP to further enhance CoMP air-interface and network standardization.

Contents

1	Motivation	5
1.1	Inter-cell Interference problem in LTE network	6
1.1.1	Test Case 1: Inter-cell interference in TD-LTE trial network	6
1.1.2	Test case2: Inter-cell interference in LTE FDD network	8
1.2	CoMP techniques overview	8
1.2.1	Centralized architecture (C-RAN)	10
1.2.2	Distributed architecture (D-RAN)	11
1.2.3	DL CoMP	11
1.2.4	UL CoMP	12
1.2.5	Cell clustering	13
1.2.6	Summary of different CoMP schemes	14
2	Feedback of CoMP Development and Field Trial	14
2.1	UL CoMP Trial Results	15
2.1.1	Test case 1: Uplink Joint Detection for Intra-site CoMP in TD-LTE network	15
2.1.2	Test case 2: Uplink Joint Detection in LTE FDD network	16
2.1.3	Test case 3: UL CoMP Field Test	19
2.1.4	Test Case 4: UL CoMP Test in Hetnet	20
2.2	DL CoMP Trial Results	22
2.2.1	Test case 1: Smart LTE (Centralize coordination)	22
2.2.2	Test case 2: Downlink Coordinated 3D Beamforming	25
2.2.3	Test case 3: Downlink Non-coherent CoMP JT	26
3	Study on CoMP in C-RAN	28
3.1	Reference centralized architectures	29
3.2	Performance assessment	30
3.2.1	Influence of the cooperation cluster size on DL CoMP	30
3.2.2	Influence of the cooperation cluster size on UL JR	32
3.2.3	Joint reception for Heterogeneous NW	32
3.3	Recommendations and concluding remarks	36
4	Study on CoMP over non-ideal backhaul	36
4.1	CoMP Architectural Options in the non-ideal backhaul environments	37
4.1.1	Distributed CoMP Architecture	37
4.1.2	Centralized CoMP architecture	37
4.2	CoMP signalling type	38
4.2.1	One-Way signalling	38
4.2.2	Two-Way Signalling	38
4.3	Possible solutions for CoMP with NIB	39
4.3.1	Study case 1: CSI exchan	39
4.3.2	Study case 2: Autonomous Muting	40
4.4	CoMP Architectural Analysis	41
4.4.1	Time Synchronization	41
4.4.2	Backhaul Latency	42
4.4.3	Backhaul Bandwidth	45
4.5	Performance evaluation	47
4.6	Concluding Remarks	47
4.7	Operators' view on CoMP with non-ideal backhaul	47
5	Challenges and Considerations of CoMP	48
5.1	Challenges of CoMP implementation	48
5.2	Requirements of CoMP commercialization	48
6	Conclusion	49



Appendix	50
APPENDIX I Simulation Parameter for C-RAN Evaluation	50
APPENDIX II: Performance Evaluation in different CoMP Architectures	52
A2.1 Evaluation results of CoMP with non-ideal backhaul by 3GPP	52
A2.2 Comments on evaluation results of 3GPP	56
A2.3 Evaluation of centralized CoMP in a realistic environment	58
A2.4 Evaluation of the autonomous muting with different backhaul latency	60
Glossary of Definitions and Terms	63
References	64

1 MOTIVATION

The LTE network is usually deployed with adjacent cells using the same frequency band, which significantly improves the frequency utilization efficiency. However, the cell-edge users may suffer throughput loss due to severe inter-cell interference (ICI). With the rapid growth of user terminals in the commercial LTE networks, ICI levels are rising and ICI is becoming the dominating factor of the network capacity. Advanced ICI mitigation or exploitation techniques therefore offer high potential to improve end-user conditions.

Coordinated multipoint processing (CoMP) is regarded as an effective method to solve the problem of inter-cell interference and improve the cell-edge user throughput. With the CoMP technology, several neighboring cells could be jointly processed or coordinated for cell-edge users in order to avoid interference and improve cell-edge users' throughput.

In order to well understand real performance and provide a recommendation or guideline to the industry, the main scope of the CoMP Workstream includes:

- Gather feedback from current trials and prototype system on CoMP to understand real performance and possible improvements and any implementation issues.
- Investigate the benefits, concerns, technical challenges, and requirements of different CoMP schemes with both C- RAN architecture (ideal backhaul) and traditional RAN architecture (non-ideal backhaul)
 - Identify any impact on the performance of CoMP schemes for different C-RAN architectures and suggest any improvements that might be useful.
 - Analyze and recommend architecture evolution options in support of CoMP operation between DUs.
- Provide a recommendation and a guideline to the industry to fill the gap between current standardization and commercialization.

1.1 Inter-cell Interference problem in LTE network

Due to the transmission power loss and inter-cell interference, the cell-edge throughput is much lower than the cell-average. Therefore, it's critical to improve the cell-edge throughput in order to improve the user's experience.

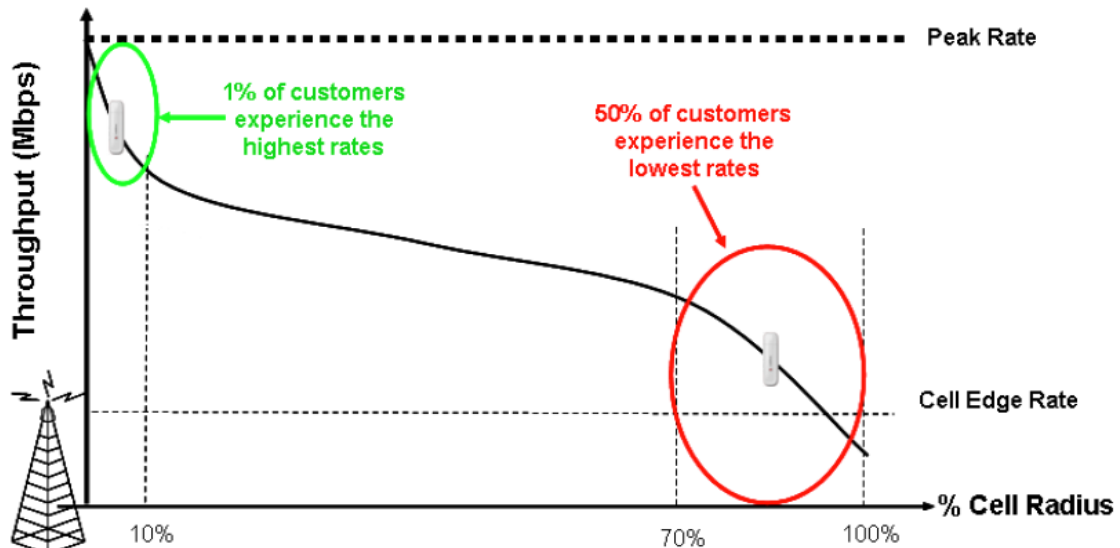

(Source: Vodafone)

Figure 1 The users experience significant rate decrease at cell edge areas.

1.1.1 Test Case 1: Inter-cell interference in TD-LTE trial network

In the large-scale field trial of China Mobile's TD-LTE network, we analyze the inter-cell interference in an urban area, where 40 sites with a total of 120 cells are deployed in D band with the inter-site distance around 300–500m.

In the drive-test, we use the commercial dongles to record the detected cells and analyze the reference signal received power (RSRP) of each cell. The statistics of detected neighboring cells are shown in Figure 2. It's observed that 88.7% of the testing points could detect at least one neighboring cell, and in some cases up to 6 neighboring cells. Meanwhile, 34.2% of the testing points could detect neighboring cells from the same site of the serving cell. It's also observed that only 2.8% of the testing points could detect all three cells of the same site.

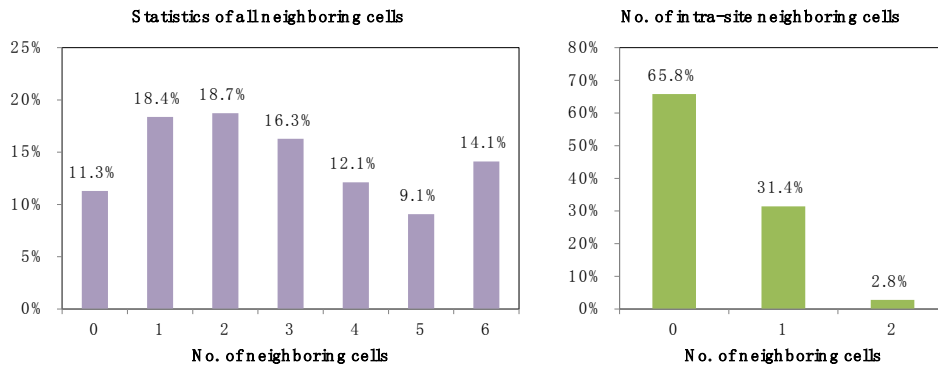

Figure 2 statistics of detected neighboring cells

Considering CoMP technology, only the neighboring cells with RSRP above certain threshold could be utilized for joint transmission or scheduling. We re-count the number of neighboring cells with different RSRP thresholds, which is defined by $\Delta\text{RSRP} = \text{RSRP}_{\text{serving-cell}} - \text{RSRP}_{\text{neighboring-cell}}$. The statistical results are shown in Figure 3. The

percentage of detecting at least one neighboring cell is 71.8%, 42.1%, 22.6% for 10dB, 6dB, 3dB threshold, respectively.

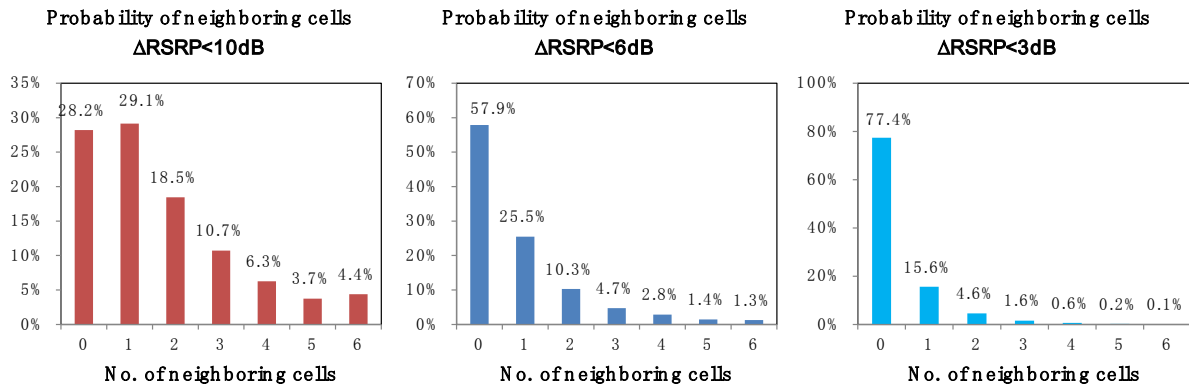

Figure 3 Number of neighboring cells with RSRP constraint

Observations:

- (1) 88.7% of the testing points could detect at least one neighboring cell and 34.2% of the testing points could detect neighboring cells from the same site of the serving cell.
 - a) Only 2.8% of the testing points could detect all three cells of the same site.
- (2) The percentage of detecting at least one neighboring cell is 71.8%, 42.1%, 22.6% for 10dB, 6dB, 3dB threshold, respectively.

Conclusions:

- (1) A considerable percentage of users could benefit with joint processing or scheduling.
- (2) For intra-site CoMP, only one neighboring cell is selected as CoMP cell in most cases.
- (3) The RSRP threshold for CoMP cell selection may be reasonable to be 3~6dB.

To evaluate the inter-cell interference in the TD-LTE network, we record the downlink detected SINR with different network downlink traffic load. The cumulative density function (CDF) curve for SINR is illustrated in Figure 4. It's observed that the average SINR is decreased by 5.3dB and 8.3dB with 50% and 100% traffic load, respectively.

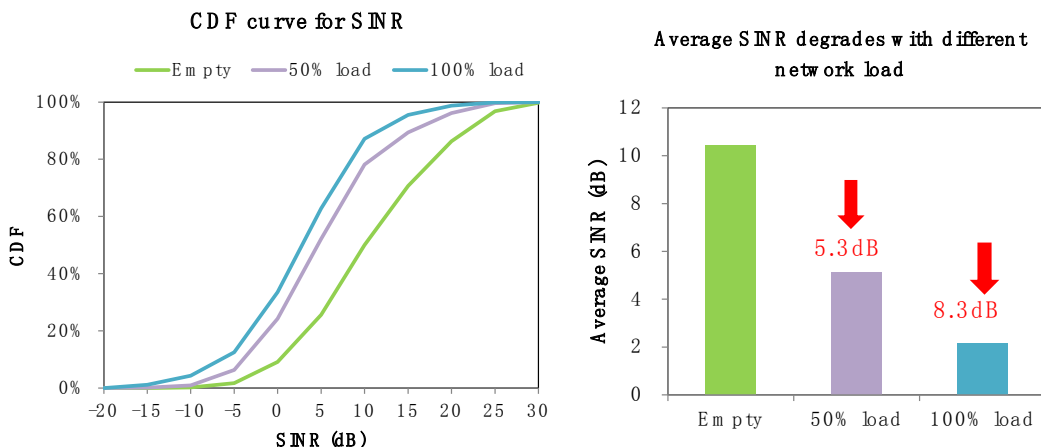

Figure 4 SINR with different network traffic load

Observations:

- (1) The average SINR is decreased by 5.3dB and 8.3dB with 50% and 100% traffic load, respectively.

1.1.2 Test case2: Inter-cell interference in LTE FDD network

Similar effects are seen in a LTE FDD network as those already illustrated for TDD.

The degradation of cell capacity, cell edge UE throughput and SINR in a LTE FDD network as a result of rising ICI level with increasing load is shown in figure 5 below.

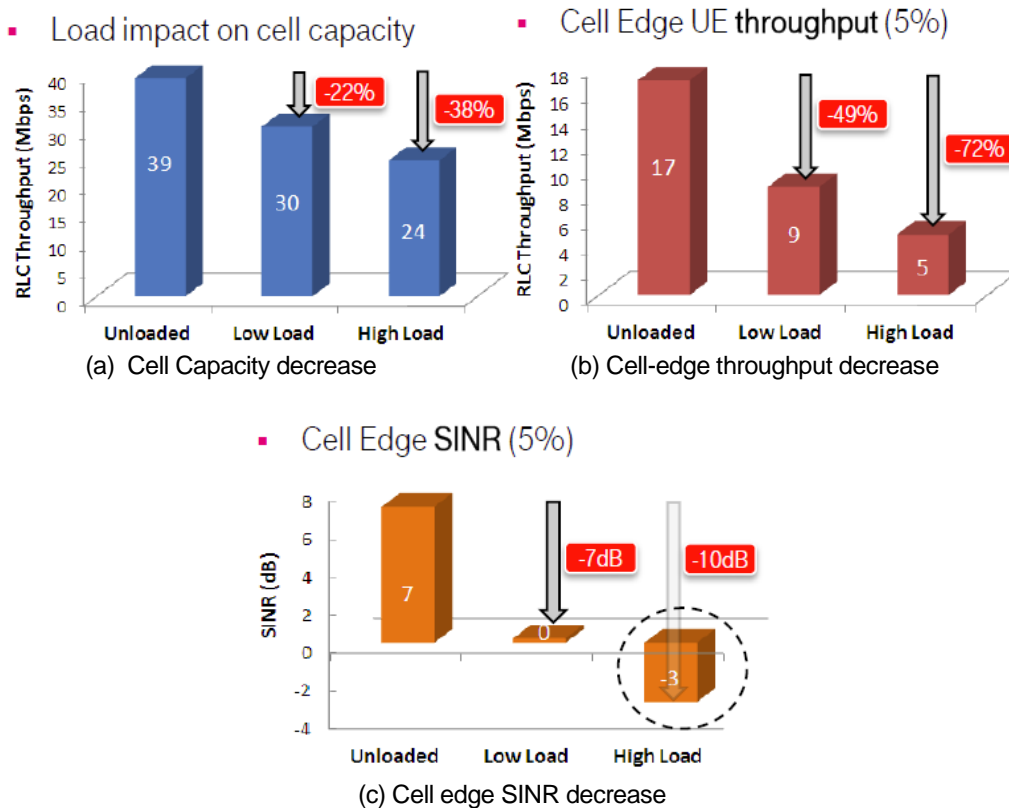

Figure 5 System performance decrease with inter-cell interference

Observations:

- (1) Significant capacity degradation is caused by inter-cell interference, with 22% degradation when low load and 38% degradation when high load.
- (2) The throughput degradation is even bigger for cell edge users, with 49% degradation when low load and 72% degradation when high load.
- (3) The very low SINR when high load will cause higher risk for handover success rate, which also causes high risk for VoLTE service.

1.2 CoMP techniques overview

Coordinated multipoint processing (CoMP) is regarded as an effective technology to solve the problem of inter-cell interference and improve the cell-edge user throughput. There are a series of CoMP technologies with different algorithms in different scenarios. In Figure 6, an overview of different CoMP technologies is illustrated.

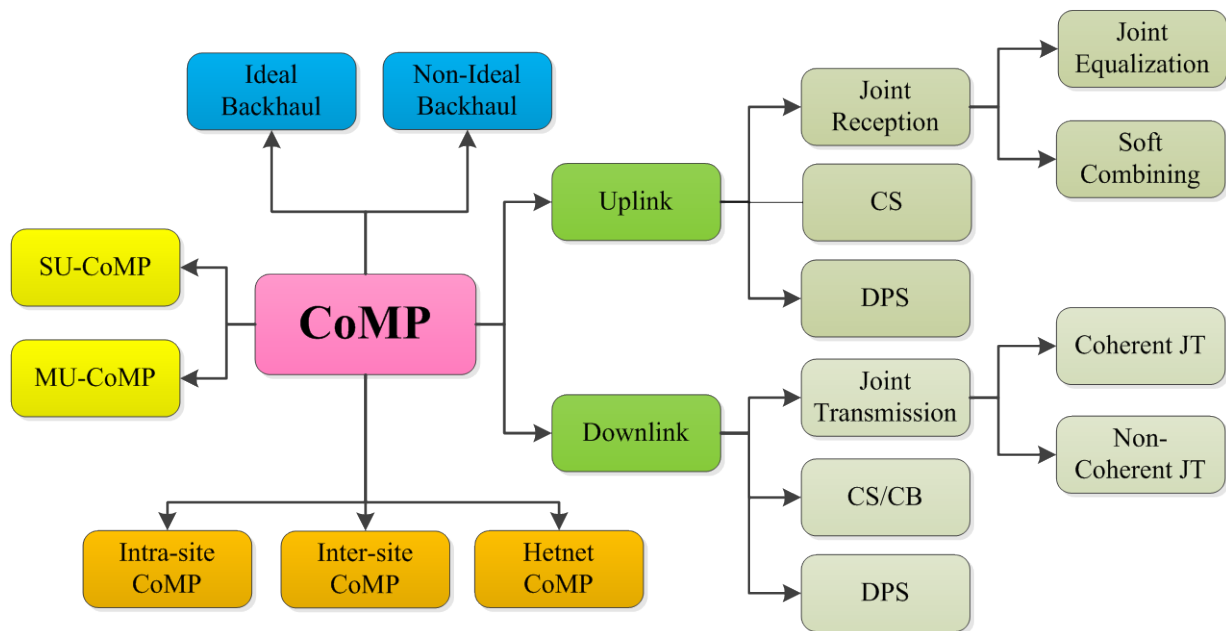

Figure 6 category of the CoMP technologies

Cooperative Multipoint (CoMP) transmission and reception is a framework that refers to a system where several geographically distributed antenna nodes cooperate with the aim of improving the performance of the users served in the common cooperation area. CoMP encompasses all required system designs to achieve tight coordination for transmission and reception and it is expected to improve the coverage of high data rates and the cell-edge throughput, reduce the inter-cell interference as well as to increase system throughput. CoMP can be then defined as multiple transmission points collaboratively transmitting data in downlink, and/or multiple reception points collaboratively receiving data in uplink. CoMP is applied in the downlink by performing a coordinated transmission from the base station, whereas interference in the uplink can be reduced by means of a coordinated reception in eNBs.

The basic idea behind CoMP is to extend the conventional single-cell to multiple-UEs transmission to a multiple-cell-to-multiple-UEs transmission by base station cooperation. Interference from neighboring cells substantially degrades performance compared to what can be achieved in a single-cell scenario and it is also recognized that reducing the interference from only one neighboring cell can significantly improve the performance.

Different CoMP categories require different levels of coordination in terms of channel state information (CSI) and data sharing, e.g., sharing both CSI and data, either or neither of them where each entails different CoMP operation costs, such as the backhaul limit, thus providing different performance gains.

The main critical issues affecting CoMP performance may be then listed as:

- Backhaul latency
- CSI (Channel State Information) reporting and accuracy
- Network complexity

Two kinds of architecture can be distinguished with respect to the way this information is made available at the different transmission points: centralized baseband (C-RAN) and distributed RAN with non-ideal backhaul. In the distributed RAN architecture, two kinds of coordination methods could be distinguished with or without a central coordinator, as shown in Figure 7-2-a and 7-2-b. Both types of RAN architecture can be combined with any of the different CoMP transmission schemes presented in next sections, although the degree of complexity to implement them may vary from one scheme to the other.

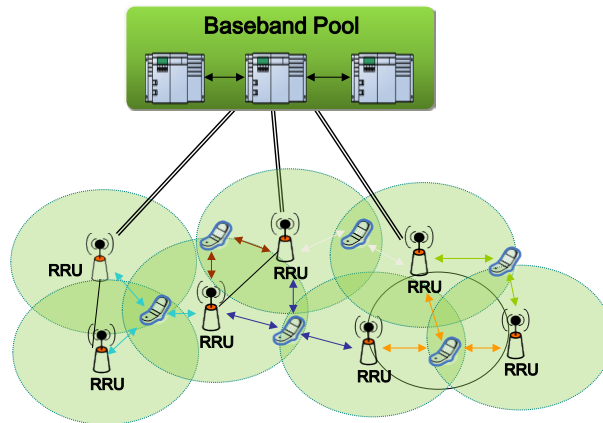

(1) CoMP in C-RAN

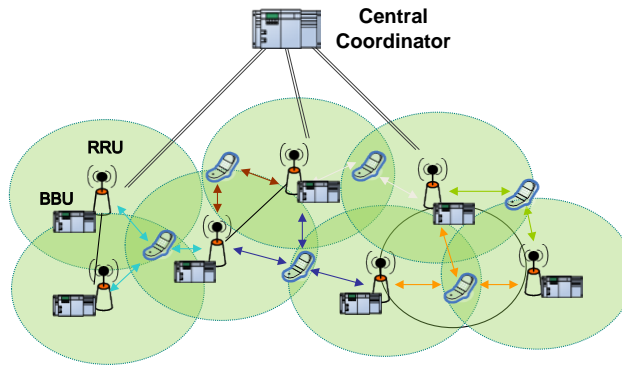

(2-a) CoMP in distributed RAN with central coordinator (central coordinator is only the layer 2 scheduler)

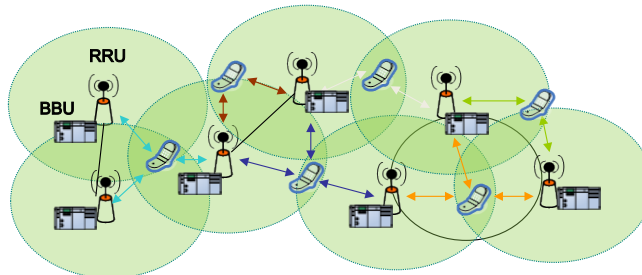

(2-b) CoMP in distributed RAN without central coordinator

Figure 7 CoMP in different RAN architectures

1.2.1 Centralized architecture (C-RAN)

In the C-RAN architecture, a central entity is needed in order to gather the channel information from all the UEs in the area covered by the coordinating eNBs, user data could be available at all collaborating nodes. In an ideal implementation, this entity is also in charge of performing user scheduling and signal processing operations such as precoding. Furthermore, tight time synchronization among eNBs is needed. On the downlink of FDD systems, the UE needs to estimate the channel and derive channel coherent or non-coherent indicators (CSI/CQI) to feed back to the eNB. In TDD systems, the channel information can be improved and/or simplified by using channel reciprocity features. In the case of FDD operation, terminals must first estimate the channel related to the set of cooperating eNBs. The information is fed back to a single cell, known as the anchor cell, which acts as the serving cell of the UE when coordination is being employed. The support of coherent joint transmission for FDD will not be provided in R12.

Once the information is gathered, each transmission point forwards it to the central entity that is in charge of deciding the scheduling and the transmission parameters, and this new information is sent back to the eNBs.

The main challenges of this architecture are related to the new associated communication links between the central entity and the eNBs. They must support very-low latency data transmissions and in addition communication protocols for this information exchange must be designed.

1.2.2 Distributed architecture (D-RAN)

A distributed architecture is another solution to perform coordination which has potential of minimizing the infrastructure and signaling protocol cost associated with eNBs' links and the central processing unit, so conventional systems need not undergo major changes. Furthermore, the radio feedback to several nodes could be achieved without additional overhead.

Different possible CoMP schemes are envisioned for both downlink and uplink. Independently of whether the architecture is a distributed or a centralized one, different approaches with different levels of coordination exists. Their requirements in terms of measurements, signaling, and backhaul are different, where as usual the highest performance achieving schemes require the highest system complexity. In the next sections the different CoMP schemes are described.

1.2.3 DL CoMP

In DL CoMP scheme (excluding CS/CB) more than one cell transmits signals in a coordinated manner to a UE as if where a single transmitter with multiple antennas geographically distributed. Cells are clustered (either flexible cluster or more easily fixed clusters) coordinating DL TX among all of them.

1.2.3.1 Coordinated scheduling and beamforming (CS/CB)

CS/CB is a kind of beam coordination among coordinated cells that dynamically reduces the dominant interference from interfering cells, data for an UE is only available at and transmitted from the serving eNB one point in the CoMP cooperating set (DL data transmission is done from that point) for a time-frequency resource but user scheduling/beamforming decisions are made with coordination among points corresponding to the CoMP cluster eNodeBs.

Coordinated scheduling aims at increasing UEs' SINR by coordination of the time and frequency resources allocated to the UEs located in different cells. This coordination can be done at the TTI level or at a longer time scale.

Beam coordination tunes the interfering beam toward a null space of the desired signal, thereby nullifying the interference to the UE, and otherwise avoids pointing the beam toward the direction that has high correlation, which can be done for example by reporting a recommended precoding matrix index (PMI) and a restricted PMI, respectively.

For CS in the central coordination method, one entity (usually one of the cells in the cluster as a master cell) assumes partial (i.e. without explicit user scheduling but only coordinating resource allocation to suppress inter-cell interference) or full scheduling functionalities of all the BSs in the cluster. For this technology to work, all DL CSI (Channel State Information) from all cells to the targeted UEs are needed. Therefore, mechanisms should be implemented for the UE measured CSI to be sent to master cell. Any UE is served only by one cell, and therefore user data only needs to be present at its serving cell. For CS in the distributed coordination method, the DL CSI-related information of the targeted UEs should be shared among the neighbor cells.

CB uses CSI to precode transmitted signals in order to avoid interference from different cells in a UE DL channel. Beamforming precoding can be done locally at each cluster cell, in a distributed joint processing way. As in the previous case, any UE is served only by one cell, and therefore user data only needs to be present at its serving cell.

1.2.3.2 Joint processing and transmission (JPT)

In Joint processing data intended for a particular UE are jointly transmitted from multiple eNBs to improve the received signal quality and cancel interference. The information theory paradigm to be exploited is the following: if antennas are uncorrelated, the number of independent communication channels is the same as the product of transmitting and receiving antennas. Different site location means inherent low correlation; hence, even though this approximation gives an upper bound for the system capacity, a high potential gain may be achievable.

Joint processing and transmission (JPT) basically changes interference signals into desired signals with a cooperation gain by combining the signals as constructively as possible over the same radio resources.

Two methods are being studied for this CoMP scheme:

- The simplest case procedure for CoMP with data available at several eNodeBs is called Dynamic Point Selection (DPS)/muting, in which the serving cell may be dynamically (from one subframe to another) changed depending on the CSIs received. Data is available simultaneously at multiple points.
- Joint Transmission (JT), where data transmission is done from multiple points (belonging to the cluster of eNodeBs) to a single UE or multiple UEs in a time-frequency reuse. Physical downlink shared channel (PDSCH) is constructed from those multiple eNodeBs of the entire CoMP cooperating set. Precoding in this context must be applied using DM-RS among the coordinating cells. Two relevant considerations should be done in this category: the serving set determination and the coherent versus non-coherent transmission approach.

In order to improve system performance in Joint Transmission data is transmitted simultaneously from different cells of the cluster, and there are two options for the coordination of these transmissions:

- (1) Non Coherent Transmission, in which the gain is obtained by pure signal power increase at the receiving UEs. Basic CSI is needed in order to support scheduling decisions, and some degree of time synchronization which will be related with the capacity of the radio interface to deal with multipath delay. The main advantage of this procedure is that phase synchronization is not needed.
- (2) Coherent Transmission, this technology takes advantage of a good knowledge of CSI, weighting PRBs allocations (Physical Resource Blocks are the minimum value of RR allocable to a UE, embracing several subcarriers along several OFDM symbols), in order to maximize the UEs received signal from several cells, being the UE able to combine coherently all received signals at symbol level. For this technology to work, a very high definition of real CSI is needed, as well as a tight time and phase synchronization among cluster BSs. This technique can be considered an advanced distributed MIMO technology. It is not currently supported by the standard, neither planned in R12.

1.2.4 UL CoMP

UEs UL signals are received at multiple geographically distributed cells, these cells are nothing but the set of coordinating eNBs assigned to each UE. This technology implements the mechanisms for coordinating schedulers of all implied cells and the received signals analysis, but the terminal does not need to be aware of the nodes that are receiving its signal and what processing is carried out at these reception points, so one of the main advantages of UL CoMP is that it can be designed not to influence in current UE specifications.

Most of the CoMP approaches share the requirement of needing some scheduling information regarding the users at the different base stations that must be shared among them. Uplink CoMP between cells hosted from the same site is fully supported in the distributed RAN approach. However, to achieve uplink CoMP between neighbor sites where baseband is at different sites, very low latency transport would be needed to support ideal approaches for joint reception. It is admitted that UL CoMP requires a centralized architecture with a low latency fronthaul, because of user plane exchanges required between reception points.

Possible alternatives for UL CoMP are then:

1.2.4.1 Interference-aware detection

No cooperation between base stations is necessary for this UL CoMP scheme; instead, base stations estimate the links to interfering terminals and take spatially colored interference into account when calculating receive filters (interference rejection combining - IRC).

1.2.4.2 Joint multicell scheduling, interference prediction or multicell link adaptation

This technique requires the exchange of channel information and/or scheduling decisions over the X2 interface between base stations. User scheduling and precoding selection decisions are made with coordination among points corresponding to the CoMP cooperating set. Data is intended for one point only.

1.2.4.3 Joint multicell signal processing

This technique has different alternatives depending on the way that decoding of terminals may take place, either in a decentralized or centralized way, and to which extent received signals are preprocessed before information exchange among base stations. There are different schemes that can be used at multiple reception points to combine the received signals: Maximum Ratio Combining (MRC), Minimum Mean Square Error Combining (MMSEC) and Interference Rejection Combining (IRC).

1.2.4.4 NICE

NICE (Network Interference Cancellation Engine) is a technique developed by Alcatel-Lucent, aiming at reducing the inter-site user plane exchanges without sacrificing performance with respect to Joint Processing. It belongs to the category of distributed successive interference cancellation techniques. [5] provides a detailed description of the algorithm, and presents some performance results.

NICE was originally defined in view of facilitating UL CoMP in distributed RAN, but it runs out that the NICE architecture greatly facilitates implementation in centralized RAN, especially for large configurations.

1.2.5 Cell clustering

In cellular networks, all users are potentially coupled by interference and the performance of one link depends on the other links. In general, a joint optimization approach is desirable but full cooperation between the users over a large network is in practice infeasible. Dynamic cell clustering to identify dominant interfering cells according to UE position is a reasonable choice and hence a limited number of cooperation cells are determined in a geographical sense to form a cooperation area. To identify candidate cooperation cells, post-CoMP SINR (SINR after CoMP), as a measure of ICI mitigation, is calculated by turning (one or two) interfering signals into the desired signal. The gain of the coordination saturates when the number of coordinating eNodeBs goes beyond some threshold value; therefore further study is required to find an exact threshold to be incorporated with UE geometry and interference level information.

The complexity dramatically increases with the number of coordinating eNodeBs. Furthermore, transport limitations such as backhaul latency and capability is also a limiting factor for cell clustering.

Cluster can be formed in a UE-centric, network-centric, or a hybrid fashion. In UE-centric clustering, each UE chooses a small number of cells that give the greatest cooperation gain. In general, UE-centric clustering is, however, very complex from a scheduling point of view. Coordinated clusters corresponding to different UEs may overlap and coordination among all overlapping clusters can span the whole network.

When the network predefines a set of cooperation cells, the cooperation area can be determined by network-centric clustering or in a hybrid fashion. In network-centric clustering the clustering is done in a static way and hence the performance of boundary UEs can be compromised, whereas in a hybrid approach multiple clusters that possibly overlap are formed but this alleviates the boundary problems among clusters by having flexibility in resource allocation between the clusters.

Comparing rate geometries with and without CoMP transmission, the choice of a better UE is considered important to enhance the CoMP gain.

1.2.6 Summary of different CoMP schemes

A summary of different CoMP schemes reported in the literature is presented in this section. For each scheme, the most adequate operational conditions (which users would benefit from its application and SINR conditions), the kind of information exchanged between cooperating nodes and both the latency and capacity requirements of the links that interconnect these cooperating nodes area identified.

The following table collects the main conclusions of the analysis:

Table 1 CoMP Schemes and associated backhaul requirements

LTE-Advanced innovation	Operational conditions	Information exchanged	Latency requirements	Inter-cell backhaul capacity requirements
Downlink				
Coordinated beamforming/ scheduling	Cell edge users, low SINR	Scheduling and global CSI info	Fast exchange of scheduling and CSI information: CSI should be distributed between the cooperating cells before the scheduling decision is taken (~4 ms)	High priority, low bitrate signalling distribution capacity required
Dynamic cell selection	Cell edge users, low SINR	Data is available at each point in CoMP cooperating set CSI info of the links of all the UEs to the cells in the cooperating set	Fast exchange of CSI information: CSI should be distributed between the cooperating cells before the scheduling decision is taken (~4 ms)	No impact on backhaul capacity Multicast capacities to be supported
Non-coherent joint transmission	Cell edge users, SINR required for the support of spatial multiplexing	Data is available at each point in CoMP cooperating set Global CSI info	Slow exchange of CSI information	No impact on backhaul capacity
Coherent joint transmission	Cell edge users, SINR required for the support of spatial	Data is available at each point in CoMP cooperating set	Fast exchange of global CSI info	No impact on backhaul capacity
Multipoint transmission	Cell edge/ inner cell users, low SINR	Data for a given UE should be distributed to the cooperating cells	Scheduling information to be distributed between cells	No impact on backhaul capacity
Uplink				
Interference-aware detection	Cell edge users	No information exchanged	No requirements	No requirements
Joint multicell scheduling	Cell edge users	Cell specific CSI and scheduling info	Compatible with the scheduling process	Low capacity required
Joint multicell signal processing - Distributed Interference Subtraction	Asymmetric interference, high SINR	Decoded codewords, MCS, assigned resources	Compatible with the decoding process (~1-2 ms)	Backhaul capacity should be increased to support the exchange of decoded codewords between cells
Joint multicell signal processing	Asymmetric interference, high SINR	Quantized received signals (I/Q signals)	Compatible with the decoding process (~1-2 ms)	Backhaul capacity should be increased to support the exchange of quantized signals between cells

2 FEEDBACK OF COMP DEVELOPMENT AND FIELD TRIAL

According to the feedbacks of all the participants, Table 2 gives an overview of the CoMP development and field trial by operators and vendors, where 'T' represents Field Trial and 'S' represents Computer Simulations. The detailed introduction to these feedbacks is concluded in Appendix A.

Table 2 An overview of the feedback of CoMP development and field trial

Companies	CoMP Schemes				CoMP architecture		
	UL CoMP	DL CoMP			C-RAN CoMP	CoMP over non-ideal backhaul	Hetnet CoMP
		JR	CS	CB			
DTAG/Samsung		T				T	T
Vodafone	T			T			
Ericsson	T						T
CMCC	T	T		T		T	T
ZTE	T	T		T		T	
ALU	T						

* T: Trial

2.1 UL CoMP Trial Results

2.1.1 Test case 1: Uplink Joint Detection for Intra-site CoMP in TD-LTE network (Contributors: Ericsson & CMCC)

The test environment of the UL CoMP is shown in Figure 8, in which PCI-124 and PCI-125 are coordinated cells. The environment is low-building residential area with multiple small streets and alleyways. The test area is at the radial direction of the cell border of the two coordinated cells. The test is using TD-LTE D band, 2Rx, 2x20W. The DL/UL configuration is 3:1.

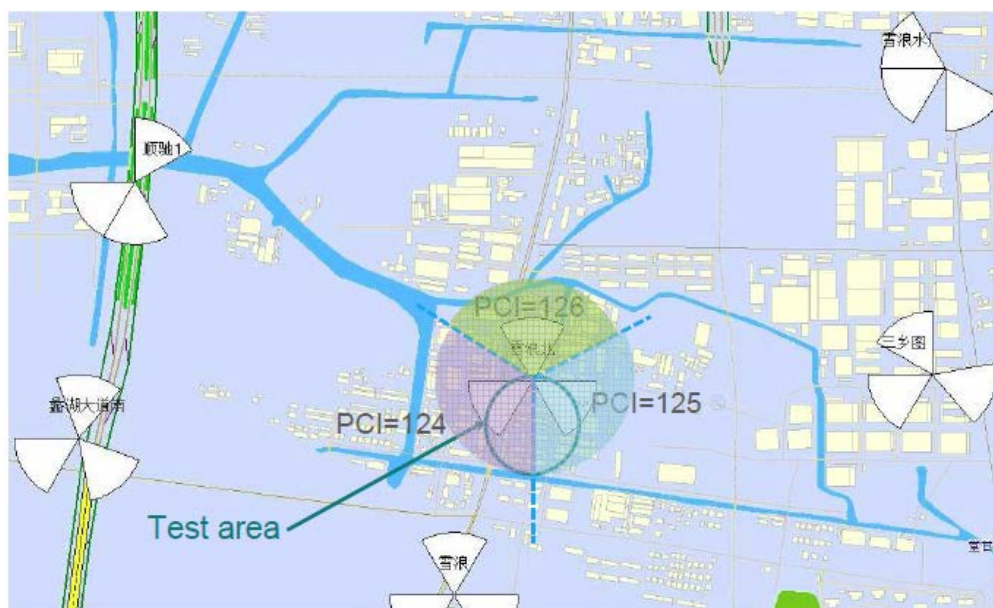
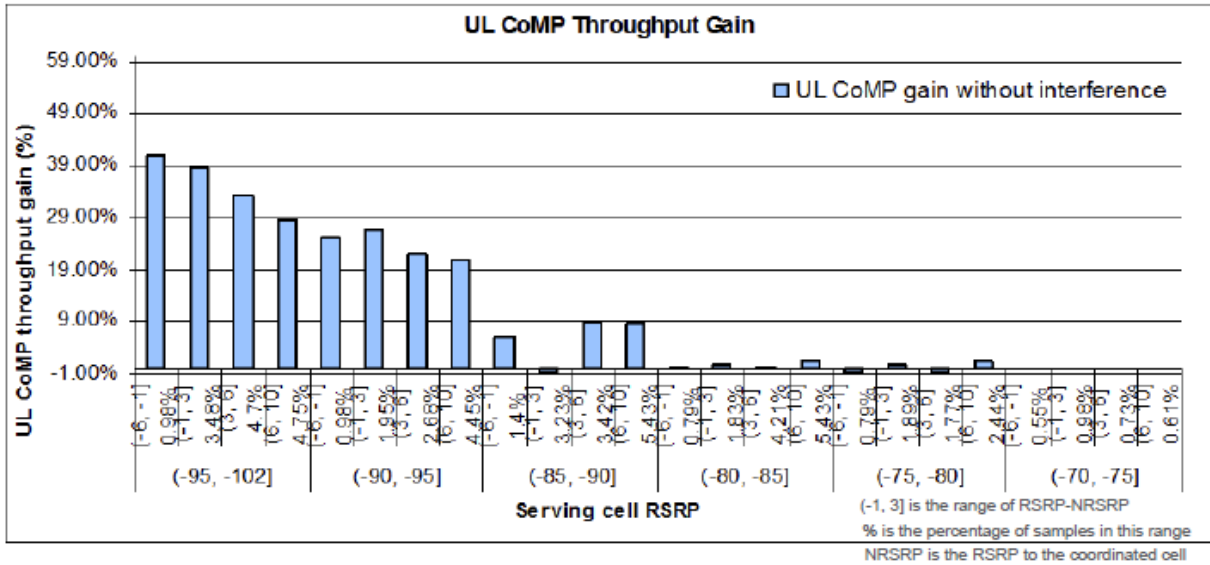
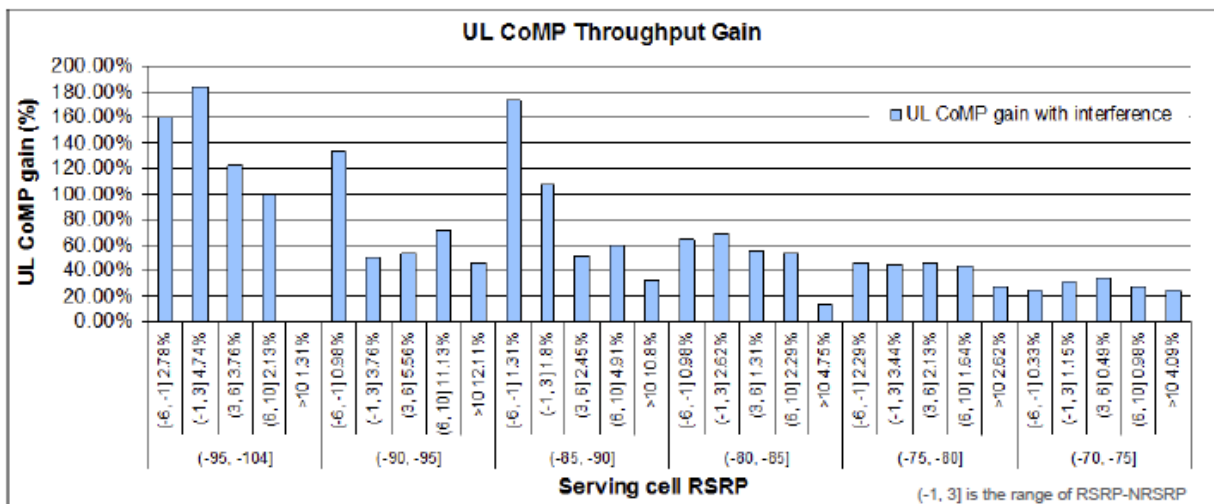

Figure 8 Test Environment of UL CoMP



(a) walk test without interference



(b) walk test with interference (IoT = 12.5dB)
Figure 9 Uplink CoMP test results

Observations:

- (1) When there is no interference, UL CoMP gain at the cell border is 20~40%.
- (2) When there is interference, 20% UL CoMP gain is seen in good coverage area, and 100% UL CoMP gain on average at handover areas.
- (3) UL CoMP can provide obvious gain in indoor poor coverage areas.

2.1.2 Test case 2: Uplink Joint Detection in LTE FDD network

(Contributors: Vodafone)

The application of CoMP in practical deployments holds many challenges, some of which are very difficult to model in the simulation studies, such as multi-cell channel estimation and the effect of channel estimation error, the backhaul-efficient multi-cell signal processing, etc. Therefore, a Vodafone test bed is built in downtown Dresden to validate the simulation results.

As shown in the figure below, the test bed in Dresden is located in an area with a typical urban building morphology that is characterized by large department of 20-50m height, a soccer stadium, a train station, railway tracks and roads up to 4 lanes. In total, 19 BSs (ISD= 450~1200m) located at seven sites with up to three-fold sectorization are used for the measurements. Each BS is equipped with a two elements, cross-polarized antenna which has 58/80° horizontal and 6.1°/7.5° vertical half power beam width. The basic physical layer procedures are used in close compliance with the 3GPP/LTE standard (3GPP TS36.211). This concerns mainly the control and data processing. However, as a major difference, we use OFDM instead of SC-FDMA in the uplink as well. Time and frequency synchronization of BS, which is required for joint detection, is done through GPS fed reference normals. The uplink carrier frequency is 2.53GHz and system bandwidth is 20MHz.

The UEs can be either carried on a measurement bus or on bike rickshaws. The current implementation of the test bed does not have any handover functionality. Thus, in order to allow for an uninterrupted trial, downlink control information such as uplink grants are sent from an additional BS, which is carried on the measurement bus as well. The received signals of all other BSs are recorded for offline evaluation, which facilitates the investigation of different linear and nonlinear detection schemes for the same recorded signals. Clearly, the focus of this approach is on physical layer evaluation. The UEs either transmit under fixed power or alternatively using LTE power control. The route travelled by the measurement car is depicted in the figure below. In this example it has a total length of 7.5 km and passes through different surroundings, such as an underpass, apartment buildings, a train station, and open spaces like parking areas. The car travelled at an average speed of about 7 km/h during measurements. The UEs continuously transmitted codewords, each spanning 1 TTI (1ms) switching cyclically between a list of MCSs (Modulation Coding Scheme). Assuming that the channel does not change significantly during the time it takes to loop through all MCSs and that there's optimal rate adaptation at the BSs, we are able to determine the instantaneous rate of the UE that would be achieved. Due to limited memory capacity, we are not able to store all the received signals at the BSs continuously. Instead, the BSs synchronously capture their received signal for a duration that's long enough for several iterations through all MCSs to obtain robust statistics of achievable rates for a small scale area.

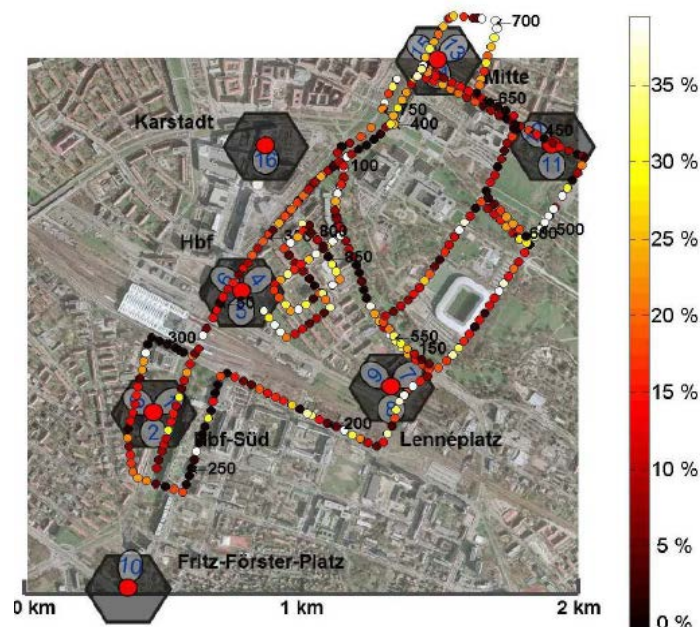

Figure 10 Vodafone UL CoMP Field Trial Test Bed in Dresden

For uplink CoMP, we investigated the performance of interference cancellation algorithms where interference was cancelled in the conventional way at a single BS using e.g. successive interference cancellation (SIC), or at a joint detector (JD), or at distributed BS after the exchange of decoded information between BSs (DSIC). The explanation for each algorithm is illustrated in the figure below.

- SIC (successive interference cancellation) is used to perform multi-user interference cancellation by utilizing an iterative loop between decoding and equalization.
- DIS (distributed interference subtraction) - Both UEs can be decoded individually by their assigned BSs, but one BS forwards decoded data bits to another for DIS.
- JD (joint detection) - one or two BSs forward all received signals to another BS where both UEs are decoded jointly. The soft value feedback from decoder is used for joint processing among cooperating eNBs.

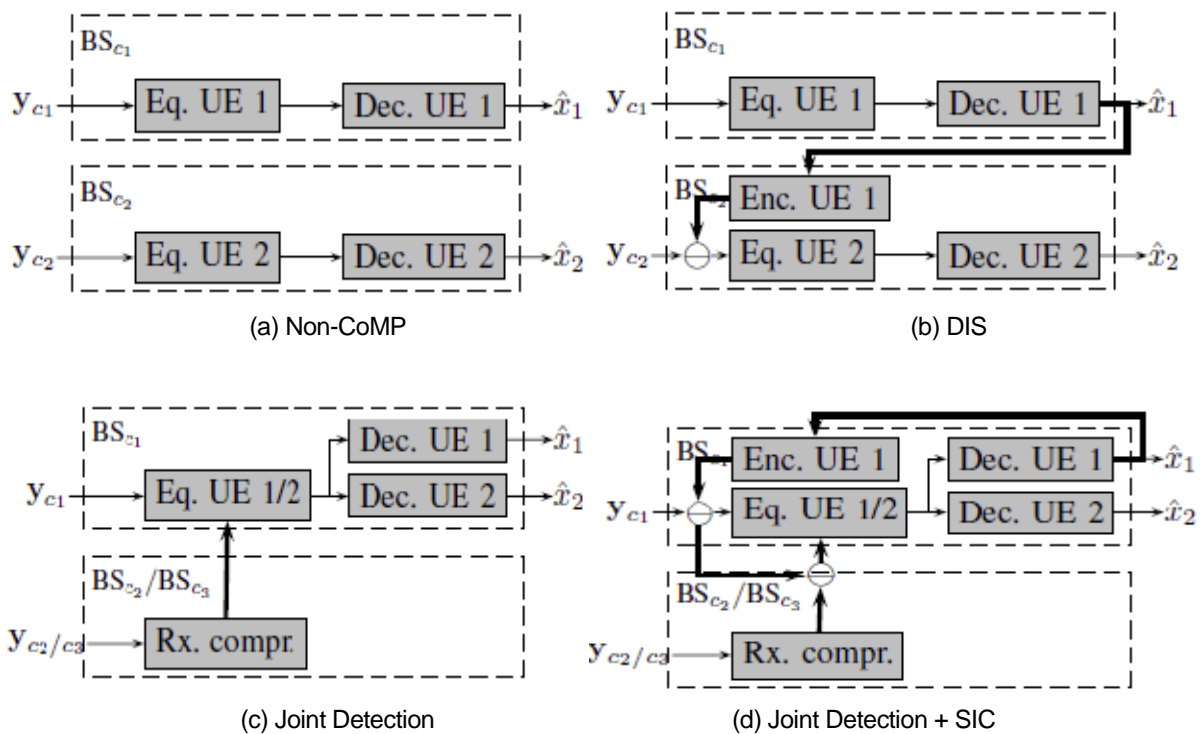
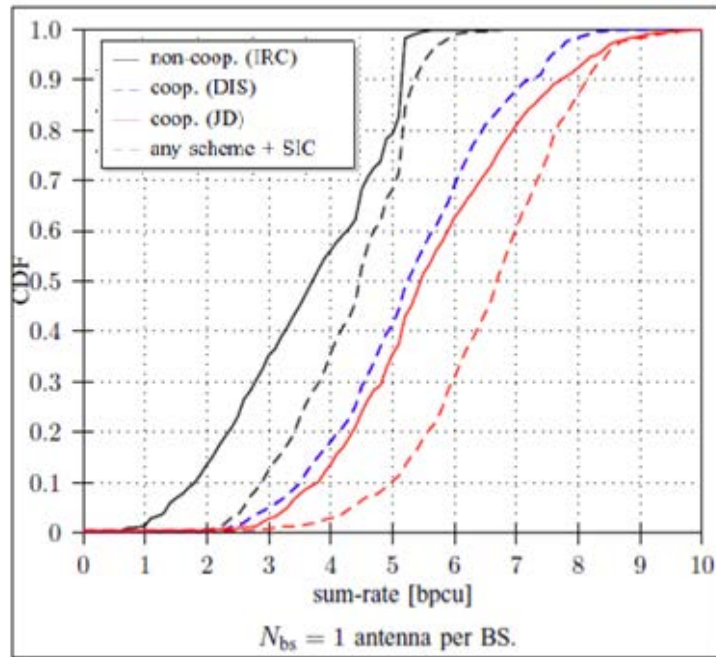
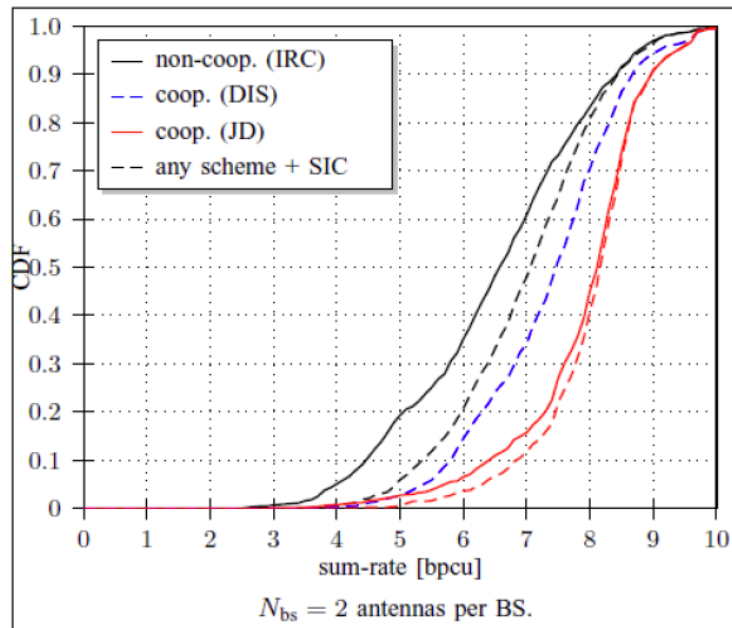

Figure 11 Different Receiver algorithms

As shown in the figure below, the successive interference cancellation (SIC) can increase average spectral efficiency by about 19% compared to non-cooperative linear detection with one antenna. On top of that multi-cell uplink joint detection (JD) yields an average throughput gain of 52%. Besides the fairly good average gain for cell capacity, the uplink CoMP can improve the cell edge performance, e.g. the cell edge user throughput gain rises over 80% in some cell edge areas in the TU Dresden field measurement compared with LTE Rel-8 baseline. The joint detection with 2 BS and 3BS can improve the system capacity significantly compared with no cooperation. Compared to joint detection (JD), the DSIC approach typically showed the lowest performance. On the other hand, DSIC makes a very effective use of the backhaul network which is massively used for JD because of the required exchanged of quantized received symbols. The detailed results can be found in [6] and [7].



(a) one antenna per BS



(b) two antennas per BS

Figure 12 Uplink CoMP test results

2.1.3 Test case 3: UL CoMP Field Test

(Contributors: ZTE)

ZTE has built a field test environment in Xi'an of China to test CoMP performance. The field test environment consists of 6 sites and 10 LTE UEs. A typical test case is shown in below figure. At this case, we compared the CoMP performance with no CoMP.

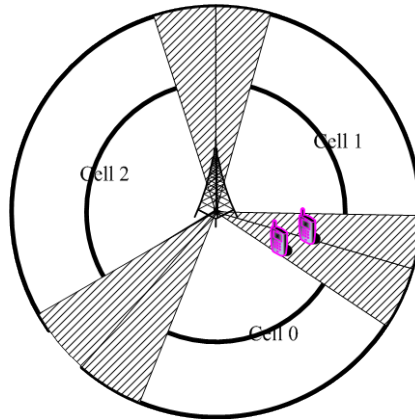

Figure 13 Test scenario for UL CoMP

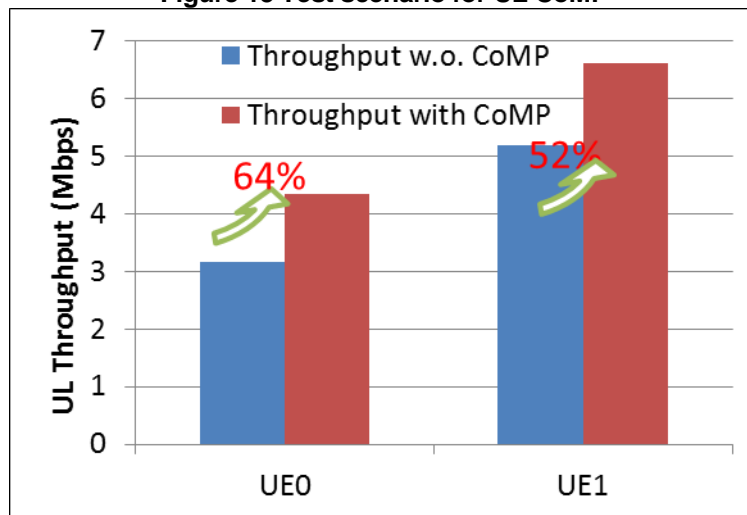

Figure 14 UL Throughput without CoMP v.s. with CoMP

Observations:

- (1) JR significantly improves the UL performance!
 - a) More than 7dB gain in the heavy load case
 - b) More than 3dB gain in the light load case
- (2) The UL CoMP gain is 14%~124% depending on UE's position.

2.1.4 Test Case 4: UL CoMP Test in Hetnet

(Contributor: Ericsson & CMCC)

The test environment includes one macro site and one micro site. The distance between macro and micro is 110m.

Table 3 Configurations for Macro and Micro BS antennas

	Max. Tx Power	Antenna config	Height
Macro	43dBm	18dBi, 61, X-pol, downtilt 6	25 m
Micro	37dBm	2dBi, Omni x 2	7 m

Table 4 Testing parameters

RRU	2-path
Duplex	TDD
UL/DL conf	2:2
Band	2.3GHz
BW	20MHz
UL Resource	48PRB

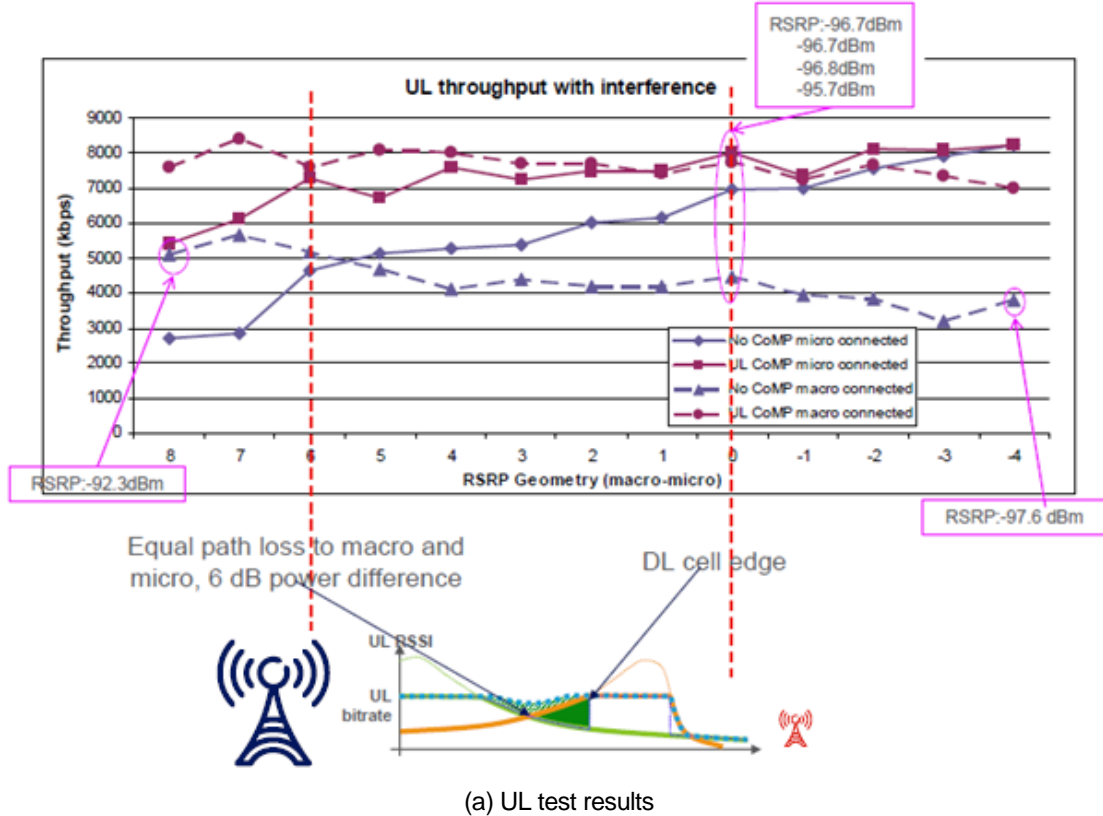

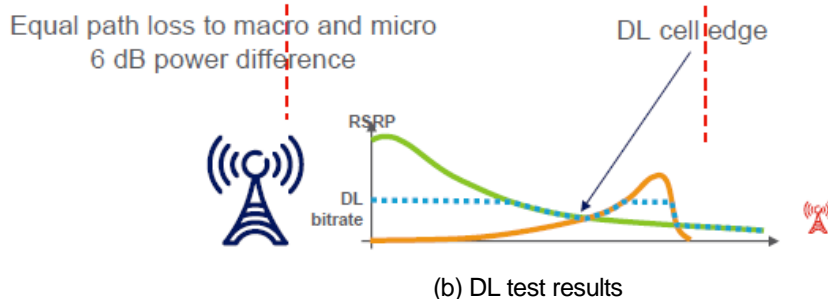
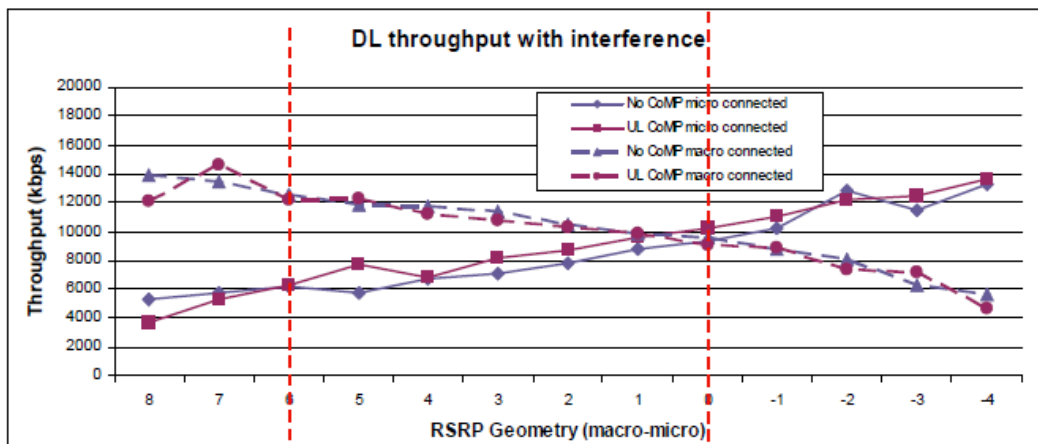

Figure 15 Hetnet CoMP Test Results

Observations:

- (1) Significant uplink gain is shown with UL CoMP in Hetnet.
- (2) Uplink/downlink decoupling gain is obtained by utilizing best links.
- (3) Significant uplink diversity combining gain could be achieved.
- (4) Up to 100% end user throughput gain for Macro-Pico cell borders.

2.2 DL CoMP Trial Results

2.2.1 Test case 1: Smart LTE (Centralize coordination)

(Contributors: DTAG & Samsung)

Samsung's Smart LTE concept introduces a new proprietary element to standard flat LTE network architecture called a Central Scheduler. The Central Scheduler coordinates the scheduling of different cells allowing more intelligent resource management over wider network area. There are two commercial implementations of Smart LTE:

- (1) Smart C-RAN: there is no latency between Baseband hotel and Centralized Scheduler (possible with ideal BackHaul – designed for C-RAN type of LTE roll-out)
- (2) Smart D-RAN: there is latency between Baseband unit located at cell site and Centralized Scheduler (designed for LTE network with non-ideal Backhaul).

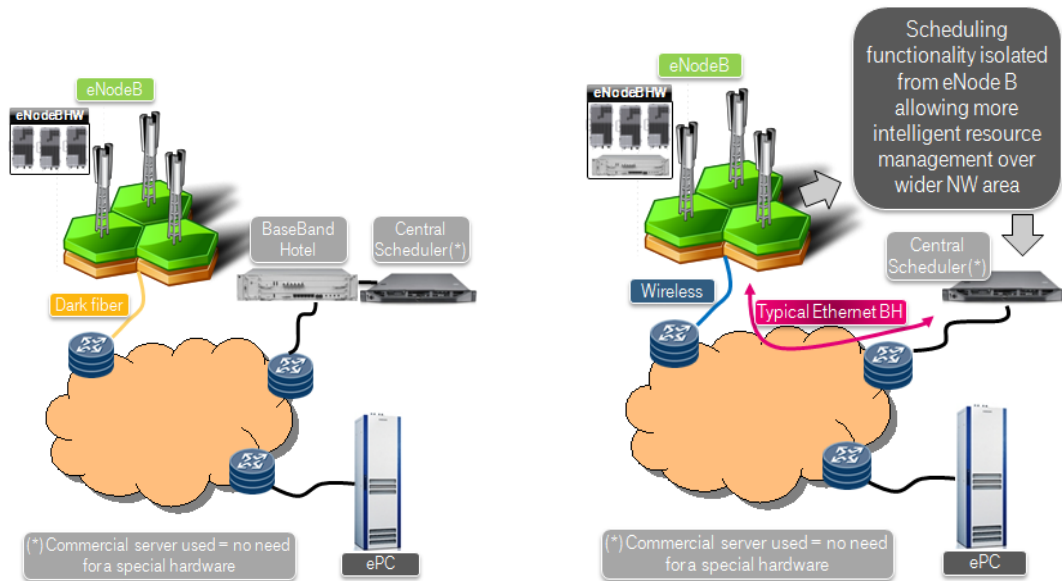

(a) Smart C-RAN network design (ideal BH)

(b) Smart D-RAN network design (non-ideal BH)

Figure 23 Smart LTE network designs

DTAG trial test bed, located in the Prague T-Mobile Czech LTE network, consisted of 12 macro sites and 3 small cells. TMCZ sites used traditional microwave backhaul, i.e. a Smart D-RAN deployment. Commercial Rel.9 compliant devices based on QUALCOMM MDM9200 chipset were used for measurement. All tests were repeated for **Conventional LTE** and **Smart LTE**. **Conventional LTE** setup was aligned with a typical DTAG **LTE Rel.9** commercial network setting applied in Q3 2012. This setup does not support frequency selective scheduling (FSS), but it should be noted that the consequential reduction of PDCCH overhead in the setup may help to counteract any lost FSS gain. Furthermore, the setup assumes full buffer traffic which largely avoids the issue of delayed coordination decisions due to backhaul latency making it hard to draw conclusions on the benefits for real-life situations. It should also be noted that the reference scheme Conventional LTE is not the best possible. It would make sense to instead compare Smart LTE with intra-site CoMP which in any case enjoys ideal backhaul and is not considered for standardization. As it stands, it is difficult to determine how much of possible gains stem from the intra-site and inter-site coordination, respectively. In addition, the setup focused on the performance of a single cell (static UEs) or a single UE (mobile UEs). In the single cell case, only one UE was on a cell edge to neighboring sites meaning that the two other UEs are likely enjoying intra-site coordination benefits and that the inter-site coordination part only has to boost the performance of a single UE similar to the mobile UEs case. It is quite natural that coordinating for the sake of only one inter-site cell-edge UE increases reported gains compared to real-life situations with a multitude of UEs in inter-site cell edge positions.

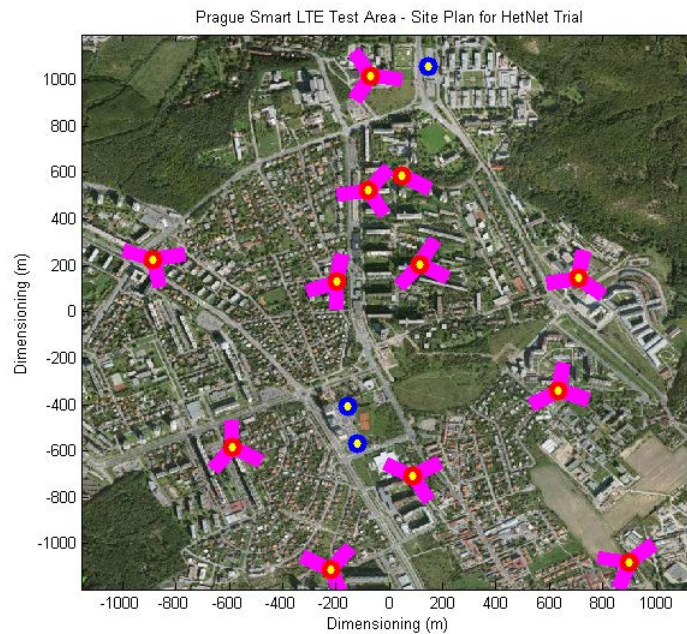
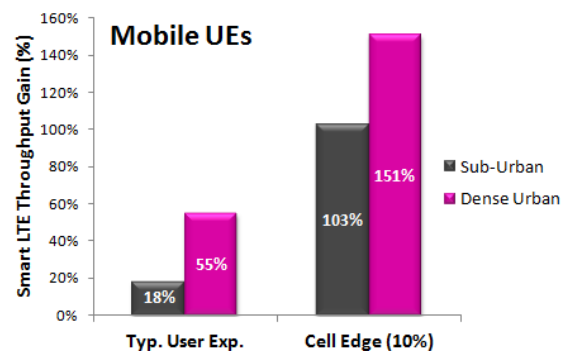
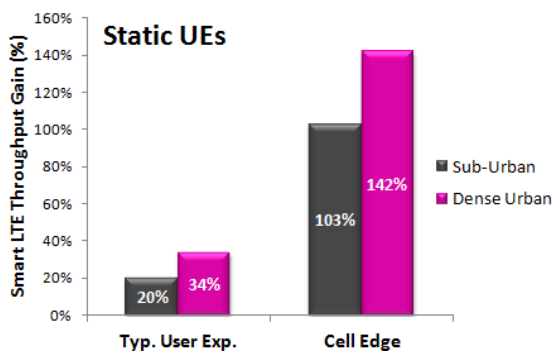

Figure 24 Prague LTE pilot network

The results of the trial observed a substantial improvement in the performance of cell edge users whilst simultaneously improving overall network capacity, when using Smart LTE. For macrocellular tests a cell edge gain of 100-150% and cell capacity gain of up to 18-35% was observed depending upon the user distribution and network density. Significant gains were also realized in heterogeneous network tests involving both macrocells and small cells. For more details please see [11]. The above results differ substantially with the results of trials DTAG has performed on ICIC methods which provided much less positive results.



(a) Smart LTE benefit for stationary users

(b) Smart LTE benefit for mobile user

Figure 25 Smart D-RAN trial result example

Observations assuming latency insensitive full buffer traffic and single UE on inter-site cell edge:

Macro environment:

- (1) **120% cell edge** and **30% cell capacity** gain observed
- (2) Not possible with standard 3GPP methods (ICIC)
- (3) Backhaul delay condition: of up to 30ms

HetNet environment

- (1) Bigger potential than Rel.10 eICIC

Conclusions:

- (1) The Smart LTE trial results from DT/Samsung demonstrate that coordinated scheduling using a centralized coordinator is an interesting technique that under very special circumstances can significantly improve cell edge performance whilst simultaneously increasing network capacity. The method was tried using Release 8 terminals, including the use of non-ideal backhaul network with comparative relaxed requirement for the delay between the eNode B and the coordinator (30ms round trip), although the full buffer traffic assumption largely avoids the issue of backhaul latency.

2.2.2 Test case 2: Downlink Coordinated 3D Beamforming

(Contributors: Vodafone)

The aim of the downlink CoMP tests in the test bed Dresden is to provide an enhanced proof of concept in a typical deployment scenario with several sites. As shown in the picture below, the test bed consist of 3 BS located at different sites in downtown Dresden, Germany. Buildings within the test bed area are almost 4-5 story apartments of similar height between 15m and 19m. In contrast, BS 1 and BS 2 are located on buildings of about three times that height. The Antennas of BS 3 are mounted in 33m height over ground. Many trees are planted along the streets which are laid out in a checkered pattern. So whether a UE has NLOS or LOS to the BSs may change quickly within few meters.

Each BS is equipped with a cross-polarized antenna. These antennas provide an electrical mechanism for changing the downtilt, which is used in addition to a pre-configured mechanical downtilt of 5°. For the measurements, a modified (OFDM based) LTE system was used, as described in [6]and [7].

Test signals with dedicated pilots were sent from the antenna system of the serving cell to a test device installed in a van. The antenna downtilt were set electrically to tilts between 5° and 17°. Several drive tests (shown as orange circle with numbers in the figure below) with defined downtilts of the serving cell have been done to get a reliable statistic and significant results. In a second step, up to 2 surrounding base stations were used as interferer for the serving cell. In a baseline measurement the interference level at the drive route was measured. Then drive tests were carried out with tilt variation between 5° and 17° of the serving cell and the neighbor cells to determine the dependency of interference of the serving cell from the downtilt of the interferers. The received signals of the drive tests with and without interference were analyzed taking the topology of the test array into account. All trials were done at 2.6 GHz with 6 MHz bandwidth.

The field measurement results in Figure 16 show that vertical beamforming could increase SIR (signal interference ratio) by about 5 – 10dB for a set of UE locations.



Figure 16 Vodafone DL 3D Beamforming Filed Test Environments

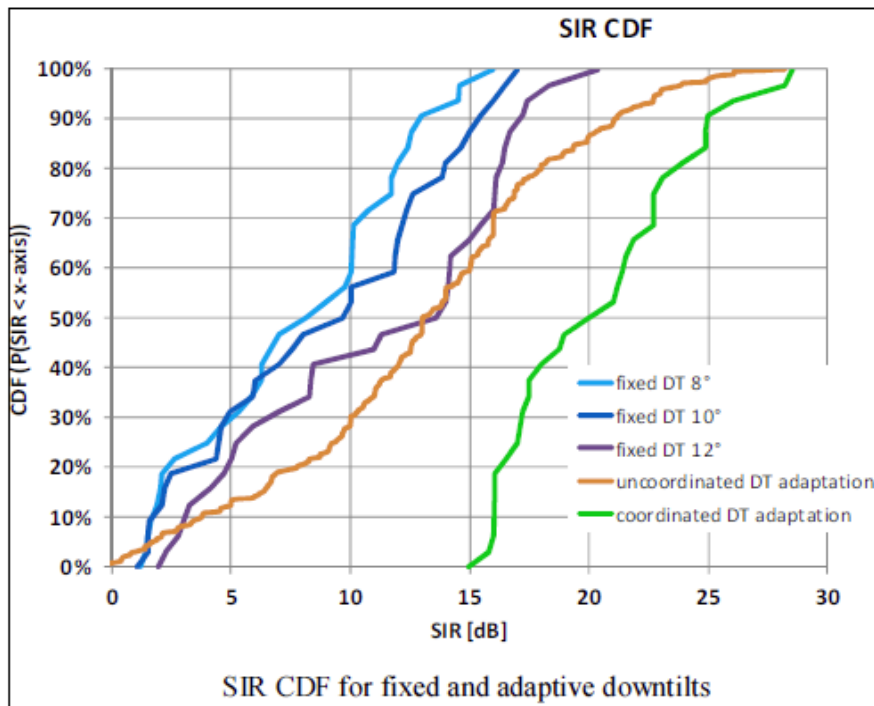

Figure 17 Vodafone DL 3D Beamforming Filed Trial Results

2.2.3 Test case 3: Downlink Non-coherent CoMP JT

(Contributors: ZTE, CMCC)

The test environment is CMCC Guangzhou Field Test Stage 1. 3 cells are in CoMP testing, and adjacent 15 cells provides loading and interference.



Figure 18 Test environment in CMCC Guangzhou Field Trial

Fix point test result:

Test Location	Serving RSRP (dBm)	Neighboring RSRP (dBm)	JT Off (Mbps)	JT On (Mbps)	JT Gain
1	-90	-90	2.04	3.66	79.41%
2	-90	-93	2.4	3.5	45.83%
3	-90	-87	0.36	3.26	805.56%
4	-105	-102	1.13	3.57	215.93%
5	-105	-105	2.49	3.68	47.79%
6	-105	-108	2.83	3.61	27.56%

Moving test result:

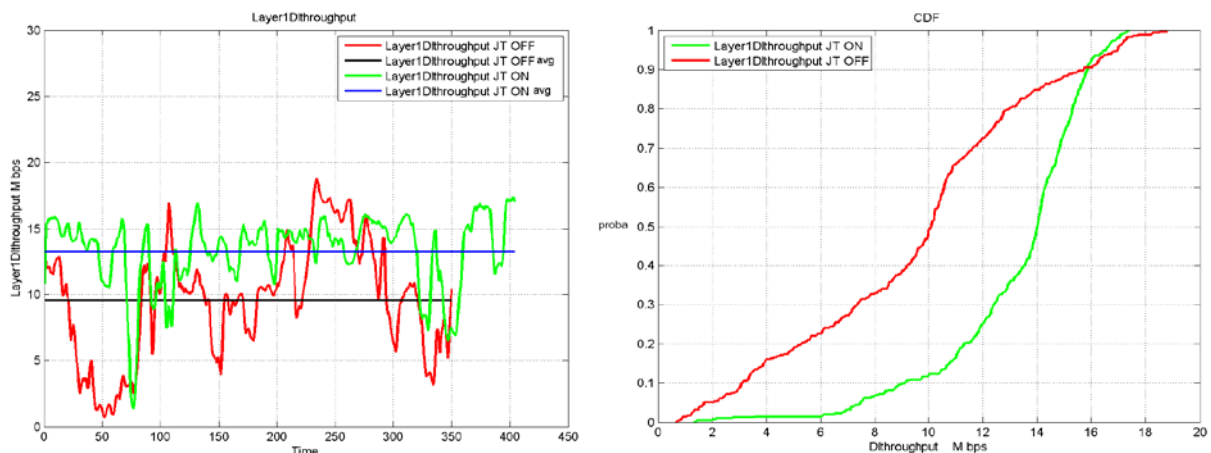

Figure 19 Test results of Non-coherent CoMP JT

Observations:

- (1) The cell-average throughput is improved by about 40% with JT on when 30% load.
- (2) The probability of UE throughput below 4Mbps decreases from 15% to 2%.

3 STUDY ON COMP IN C-RAN

It is generally recognized that centralized RAN (C-RAN) enables more efficient CoMP schemes. C-RAN makes possible very low latency and high throughput exchanges between processing units, enabling efficient multi-cell processing.

On DL, C-RAN enables or facilitates the implementation of the following features:

- Coordinated scheduling Coordinated Beamforming (CS/CB), with coordination done at TTI level; or on a few TTI time scale
- Coherent Joint Transmission (C-JT) for TDD
- Dynamic Point Selection (DPS)
- Non coherent Joint Transmission (NC-JT) in FDD or TDD
- Dynamic Cell Muting (DCM)

On UL, C-RAN enables or facilitates the implementation of the following features:

- Joint Reception (JR)
- Distributed SIC (Alcatel-Lucent technique named NICE, Network Interference Cancellation Engine)

C-JT for FDD being not supported by the standard is not covered in this section.

JR requires the transport of I/Q data received on different antennas to the same processing unit and is the most demanding in terms of signal transport and routing capability. JR drives a great part of the architecture choices. JR has also the highest performance in terms of performance improvement, and will be the main focus of this section.

In this section, we assume high speed low latency FrontHaul (FH) between the antennas and the DU pool. The maximum latency agreed in the project is 250us. There is no specific assumption made on backhaul, since its function is limited to the support of the S1 and X2 interfaces. X2 (bundle) interface ensure the connectivity to other pools or other isolated eNB.

The main dimensioning parameters of the pool are:

- The number of cells processed by the DU pool
- The maximum size of the cooperating cluster for a given UE

3.1 Reference centralized architectures

Several C-RAN architectures are considered in this section:

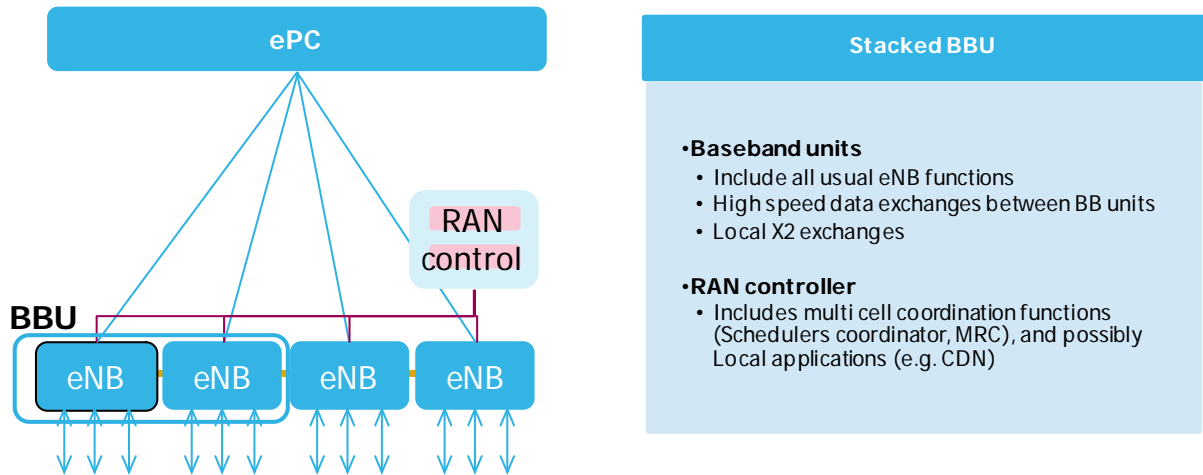

Figure 20: (A1) Stacked BBU architecture

- (A1) stacked BBU architecture represented in Figure 20. CPRI are directly connected to the BBU units. CoMP can be limited to intra-BBU processing, but inter BBU processing is also possible provided that high speed and low latency bus enable inter-BBU exchanges. In the later case, controllers in each BBU communicate with controllers in other BBU to manage the CoMP cluster and exchange scheduling information

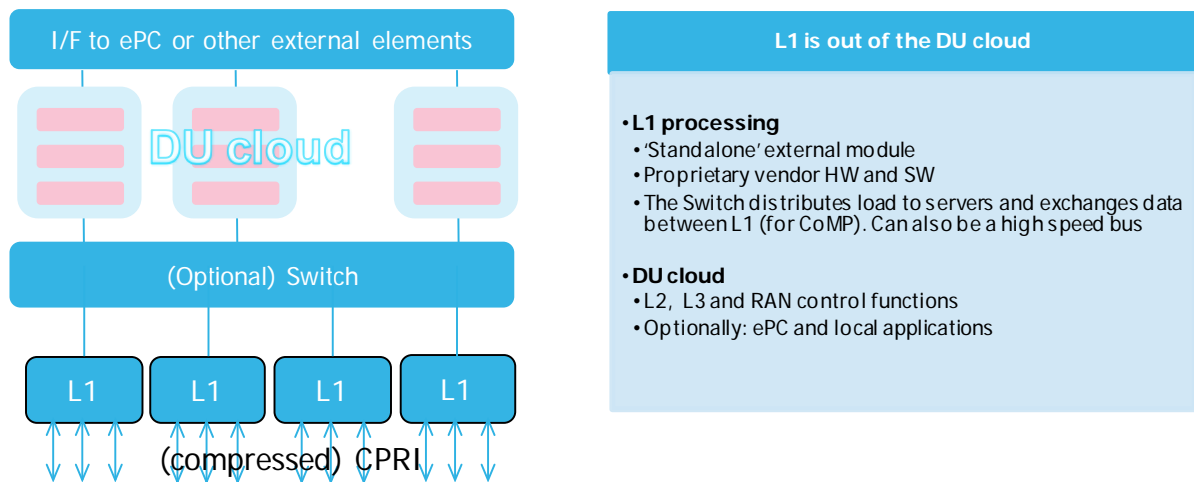

Figure 21: (A2) L1 out of the cloud architecture

Figure 21 shows architecture (A2) in which L1 processing is done in externally to the DU cloud, in specialized HW. The DU pool is in charge of L2 and L3 functions, as well as of other eNB functions. A switch is used to provide connectivity between the L1 units and the DU pool. Alternatively a high speed bus can be used to interconnect the L1 units.

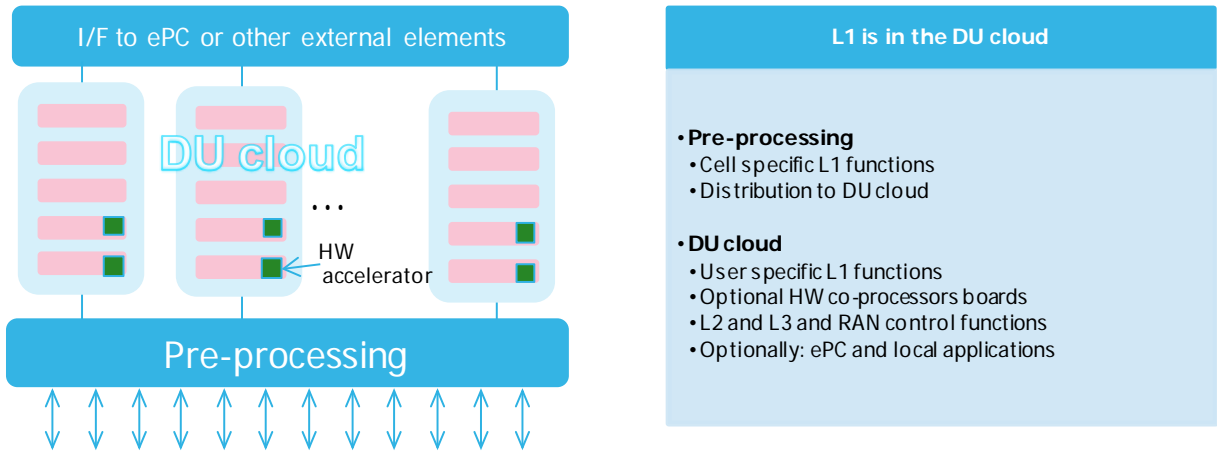

Figure 22: (A3) L1 in the cloud architecture

Figure 22 shows the most advanced architecture where L2 processing is integrated into the DU cloud. This architecture extends the pooling capability to L1. Some (or all) processing elements may include HW accelerators for L1.

Basically, all these architectures have similar capabilities regarding the capability to support CoMP. The main differences are with respect to their capability to pool resource, their energy saving potential, their scalability and future proof aspects, but have no direct impact on CoMP algorithms and performance.

3.2 Performance assessment

3.2.1 Influence of the cooperation cluster size on DL CoMP

(Contributor: CMCC)

With dynamic CoMP cells selection, only the signal strength above certain threshold, the neighboring cell is selected. The field test results have shown that with ISD =300m~500m, only 1~3 neighboring cells are selected for CoMP processing. As a result, the complexity of CoMP processing is acceptable.

C-RAN architecture is easy for data exchange, sharing channel information and scheduling information. Therefore, C-RAN could facilitate CoMP implementation

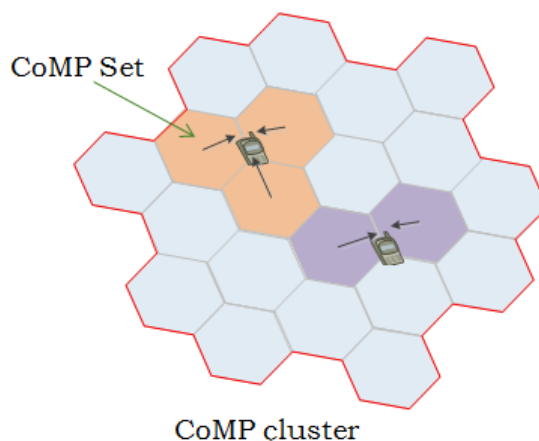

Figure 23 Dynamic CoMP cells selection

3.2.1.1 Simulations for CoMP JT

Table 5 Simulation Parameters

Duplex	TDD (DL:UL=2:2)
Antenna	BS 8Tx, UE 2Rx.
CoMP Type	dynamic 2-cells JT
Channel Estimation	SRS, non-ideal CE
Channel Model	UMi Model

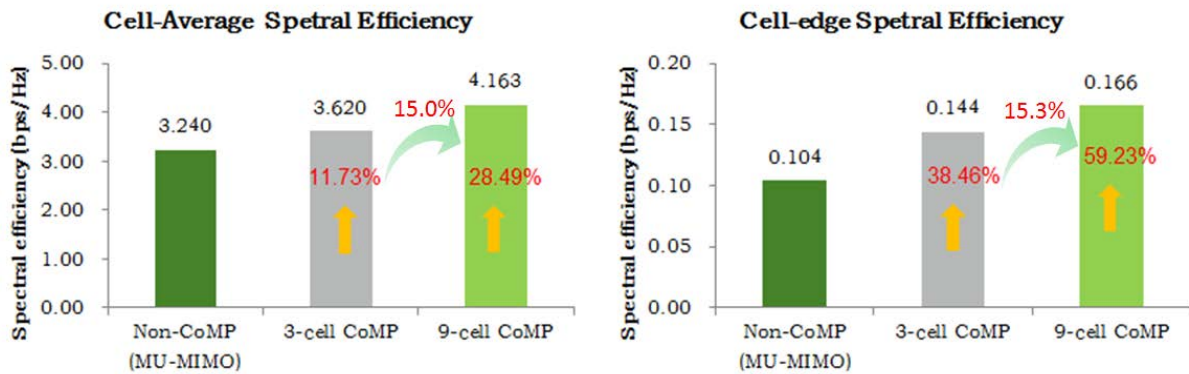

Figure 24 Simulation Results for CoMP JT

Observations:

- (1) CoMP could significantly improve spectral effectively
 - a) 38.5% cell-edge gain with intra-site 3-cells CoMP
 - b) 15% gain achieved with 3-sites 9-cells CoMP compared to intra-site 3-cell CoMP

3.2.1.2 Theoretical analysis of CoMP gain in C-RAN

A theoretical analysis has been performed to determine the impact of cooperating cluster size, when restricting the cooperation between different cells to cells within a cooperation cluster.

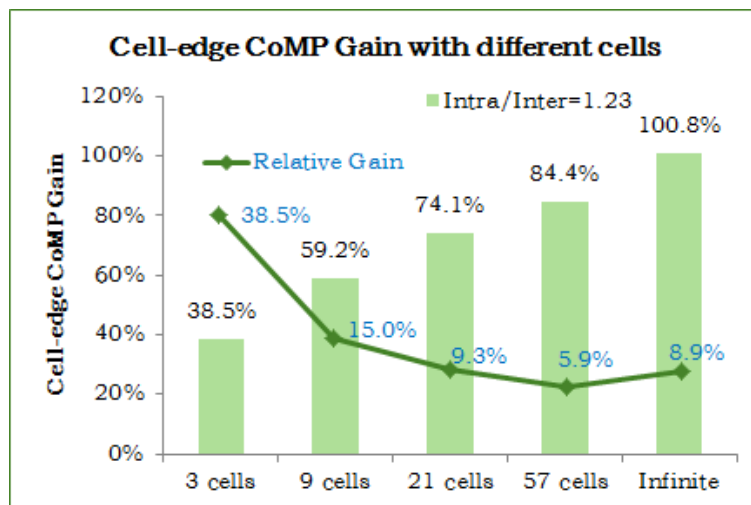

Figure 25. Cell-edge CoMP Gain with different cells

Observations:

- (1) As the scale of C-RAN cluster increases, the CoMP gain increases.

- a) 38.5% cell-edge gain for intra-site 3-cell CoMP
 - b) 15.0% relative gain for 3-sites 9-cells CoMP compared to intra-site 3-cell CoMP
 - c) 8.9% relative gain for infinite cells CoMP compared to 19-sites 57-cells CoMP
- (2) The relative gain decreases as the cluster increases.

Conclusions:

- (1) C-RAN architecture may benefit CoMP-JT implementation to avoid inter-cell interference.
- (2) With $ISD=300m\sim 500m$, only 1~3 neighboring cells are selected for CoMP set in most cases, the CoMP processing complexity is acceptable.
- (3) As the scale of CoMP cells increases, the CoMP gain also increases, while the relative gain decreases.
- (4) The scale of CoMP cluster should be determined with the trade-off between the CoMP gain and the transmission load.

3.2.2 Influence of the cooperation cluster size on UL JR

(Contributor: ALU)

The table below is an analysis of the influence of the DU pool size on JR performance. The main parameters and assumptions used are listed below:

- Full buffer traffic model
- Homogeneous macro cells
- Joint Reception with ideal channel estimation
- 2 antennas in BS

The values (10, 20 and 30 dB) represent the threshold at which a reception point is used or not for a given UE. A reception point is used for a given UE, if the receive power at the reception point considered is above $P_{serving}$ -threshold, where $P_{serving}$ is the receive power at the serving BS.

The cell edge values represent the average cell edge performance without distinguishing cells at the edge of the clusters (more degraded) from cells at the center (less degraded)

Table 6. Influence of the cluster size on JR performance

	Single Cell	3 cells cluster			9 cells cluster			Infinite cells cluster		
		10dB	20dB	30dB	10dB	20dB	30dB	10dB	20dB	30dB
UE ratio	0	22%	81%	100%	39%	81%	100.0%	57%	83%	100%
Cluster size	1	1.3	2.5	3	2.3	3.8	5.0	2.7	4.6	5.3
Avg gain	-	18%	29%	32%	25%	41%	50%	32%	49%	58%
edge Gain	-	20%	50%	45%	20%	50%	55%	40%	82%	87%

For these simulation results, we observe that cell edges gains are significantly higher when the cooperation cluster is not limited. Effects on average throughput are less dependent on the cluster size.

3.2.3 Joint reception for Heterogeneous NW

The same kind of analysis is conducted for HetNet, in view of comparing performance for several cluster sizes.

In a first approach, cooperation over several macro cells are considered, as represented in Figure 26.

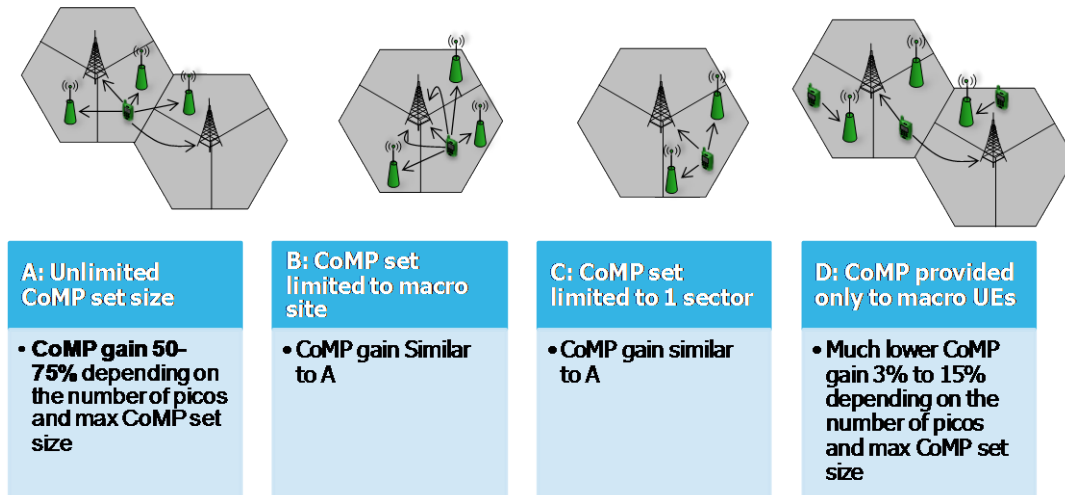

Figure 26. CoMP sets description for HetNets

In scenario A, the cooperation cluster spans over several macro cells, and is unlimited. In Scenario B, the cooperation cluster is limited to one macro cells. Scenario C limits the cooperation cluster to a single sector, and scenario D applies CoMP only for macro users (pico users operate in single receive point mode).

The simulations have been conducted for 3GPP scenarios 1 and 4b with realistic channel estimation with a full buffer traffic model. Only highly summarized results are presented in this document.

We observe that a good tradeoff consists in limiting the cooperation area to a single macro area. This suggests a Hetnet architecture where the JR processing is done in the macro BS site. Extending the cooperation area to several macro cells provides marginal improvement, mostly visible to the macro UEs at macro cell edge.

Going deeper in the analysis, we investigate now the JR gains HetNets deployments using a non-full buffer traffic model and various cooperation areas scenarios. Cooperation areas for each scenario are limited to a single macro cell coverage, based on the finding of the analysis presented above.

The key assumptions and simulation parameters are based on 3GPP 36.814. Additional assumptions are listed below:

- Hotspot scenario “4b”, with 1 pico-cell per macro
- Cross-polarized antennas, 2Rx in pico-BS, 2 or 4Rx in macros
- File size 0.5MByte (4Mbit), 8sec upload max. duration (min. throughput requirement 500kBit/s)

Figure 27 describes the 8 configurations taken into account for the NFB analysis. A and B are the (non-CoMP) reference scenarios. In D, no restrictions are made on the cooperation clusters, within the macro cell coverage. The other configurations introduce restrictions on the cooperation clusters.

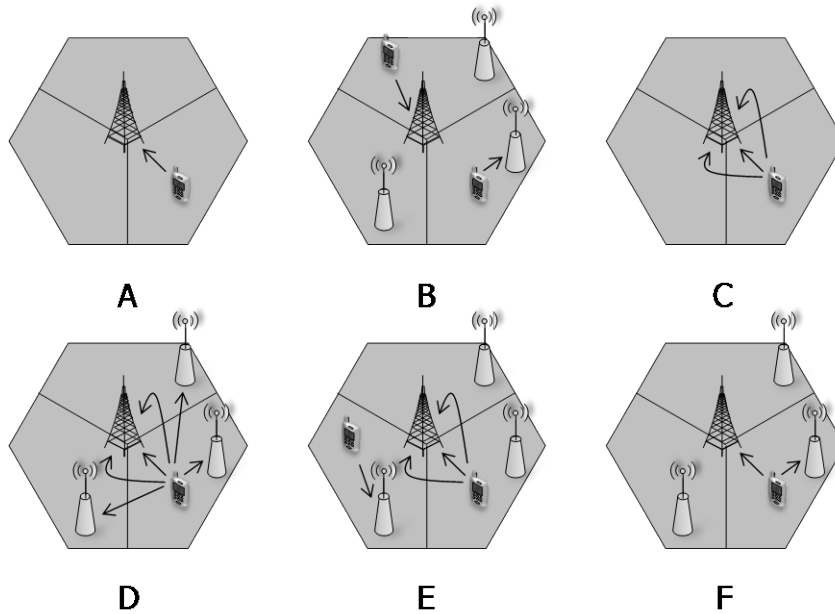

Figure 27. HetNet configurations for the NFB analysis

Figure 28 to Figure 31 presents the Cell edge and UE throughput for several user arrival rates and for 2 and 4 RX antennas in the macro BS.

The figures represent the averaged values for the whole populations of UE. When having a closer look at macro and pico UE separately (detail not provided in this document), it is observed that:

- In the low user arrival rate region, the gain for pico-UEs is limited, whereas the gain for macro-UEs is large;
- In the high user arrival rate region, the gain becomes significant for both pico and macro UEs.

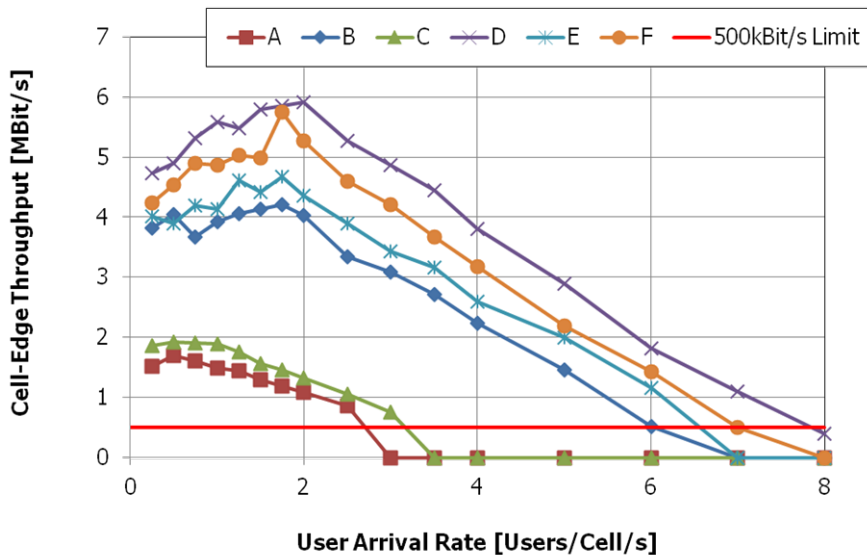

Figure 28. Cell Edge Tput. 2 RX antennas in macros

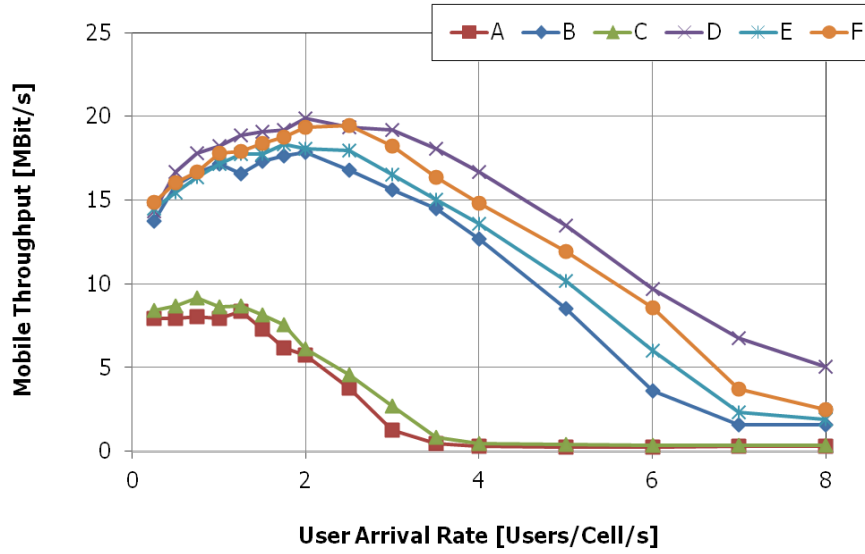

Figure 29. Mobile Throughput, 2 RX antennas in macros

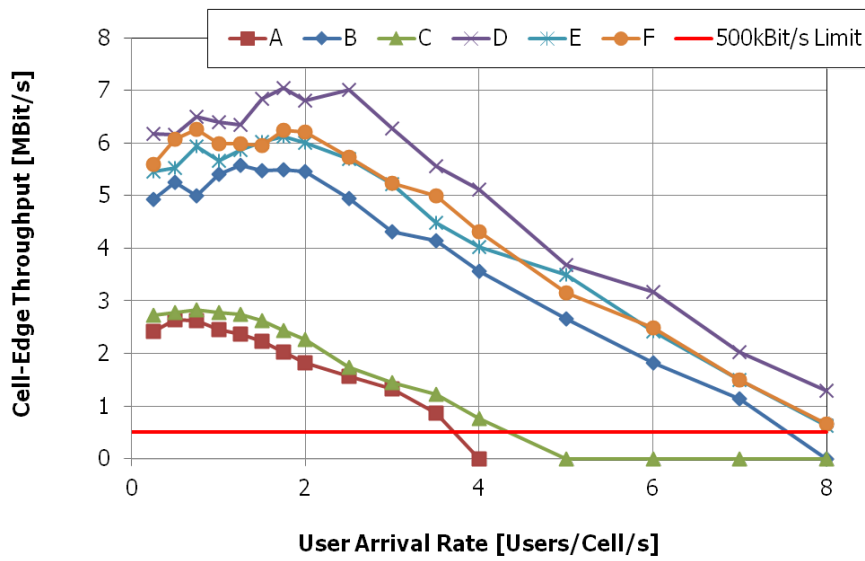

Figure 30. Cell Edge Throughput, 4 RX antennas in macros

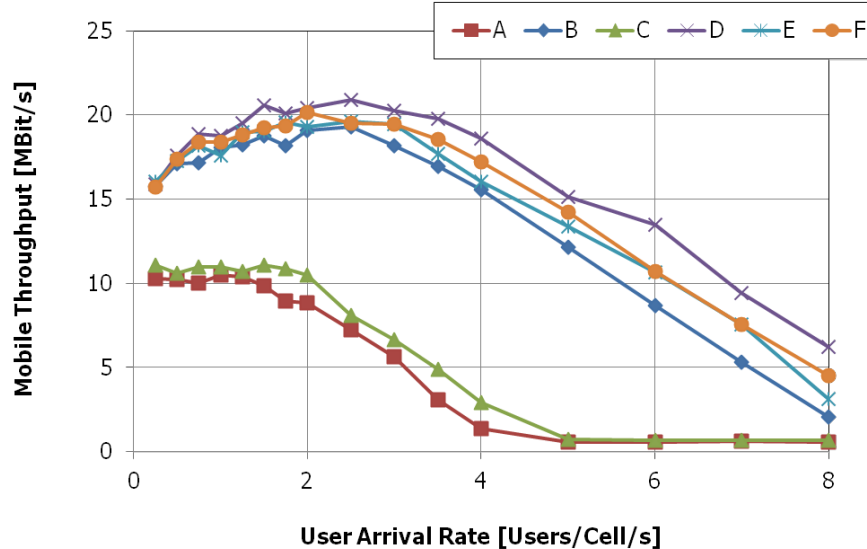

Figure 31. Mobile Tput, 4 RX antennas in macros

It is observed that:

- The introduction of a small cell boosts performance. A macro cell without pico cell cannot support a very high traffic demand. But scenario 4b, in which the density of users is higher in the pico cell coverage is favorable
- As expected scenario D outperforms E and F. Same behavior is observed for 2 and 4 antennas.
- Gains are higher at high system load
- Performance of E and F are close. The major interest of E is that it does not require pico cell fronthauling. It is therefore compatible with pico-cells with conventional backhaul.

Some complementary simulation parameters and assumptions are provided in the appendix-1.

3.3 Recommendations and concluding remarks

For homogeneous macro cell NW, JR and JT provides significant improvements. JR and JT over large cooperation cluster is easier to implement with C-RAN architecture with a low latency and high speed fronthaul. The achievement of these gains has therefore stringent implications on the system design and cost. Operation with a higher latency fronthaul is possible, but at the cost of a reduction of the peak rates by a factor of 2 at least.

In HetNets, several tradeoffs on the cooperation area have been investigated. According to this analysis it turns out that a good performance complexity tradeoff consists in limiting the cooperation area to the macro cell coverage. Furthermore, it is also shown that activating CoMP only for UE connected to macro can be a compromise. This has the advantage of authorizing the use of conventional (non CoMP) pico BS, without requiring anything on backhaul.

4 STUDY ON COMP OVER NON-IDEAL BACKHAUL

A CoMP framework is introduced in 3GPP Rel-11 to improve the coverage of high data rate and cell edge throughput. The CoMP operation in Rel-11 does not address the specified support of CoMP between eNBs with non-ideal backhaul, but is designed for ideal backhaul which has negligible latency and very high capacity. Due to this limitation, the operators having non-ideal backhaul would not be able to take performance benefit from CoMP operation. Therefore, the studies about CoMP over non-ideal backhaul have been triggered in 3GPP Rel.12 and NGMN project of RAN evolution.

This section deals with architectural analysis for CoMP over non-ideal backhaul. Before starting architectural analysis, we need to check the characteristics of non-ideal backhaul and define CoMP schemes to be adopted in non-ideal backhaul environments. Compared with ideal backhaul, non-ideal backhaul has the characteristics as follows. First, non-ideal backhaul has the limited capacity in bandwidth point of view. Second, it has non-negligible jitter and a longer latency than ideal backhaul. Last, any transport packets via non-ideal backhaul happen to be lost.

These characteristics would prevent some of CoMP schemes described in [1] from being adopted into RAN having non-ideal backhaul. JT and DPS require a tight backhaul to manage the HARQ process among multiple cells, so the two CoMP schemes are inadequate for RAN having non-ideal backhaul. Likewise, CB requires backhaul with low latency as well as high precision precoding information. Under these requirements, it is unclear whether CB could in fact provide coordination gains in non-ideal backhaul environments. For CS schemes, the wireless resources for downlink transmission of each cell participating would be coordinated to enhance the system performance. Then CS could be a promising coordination method among multiple eNBs with non-ideal backhaul. For more details, see reference [3].

4.1 CoMP Architectural Options in the non-ideal backhaul environments

Generally, two types of architectures could be considered for CoMP with non-ideal backhaul, i.e., distributed architecture and centralized architecture.

4.1.1 Distributed CoMP Architecture

In the distributed CoMP architecture, every eNB has resource coordination function module as shown in Figure 32. Each eNodeB exchanges information directly with its neighbor eNodeBs via X2 interface or any other interfaces.

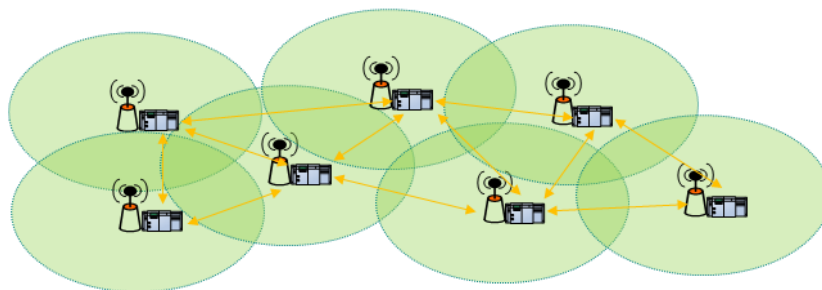

Figure 32. Distributed CoMP architecture

4.1.2 Centralized CoMP architecture

In the centralized CoMP architecture, resource coordination (RC) function module is introduced for centralized scheduling, as shown in Figure 33. Each eNodeB reports CSI-related information to the RC and the RC makes the scheduling decision and then returns to each eNodeB. The RC could be separated from eNBs or collocated with certain eNB (Master-Slave Mode).

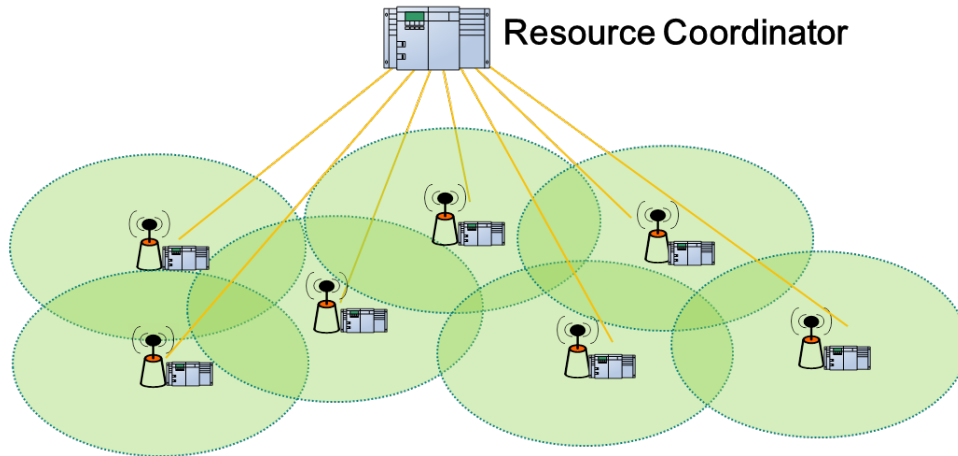

Figure 33. Centralized CoMP architecture

4.2 CoMP signalling type

There are two types of signalling exchange for CoMP with non-ideal backhaul, i.e., one-way signalling and two-way signalling.

4.2.1 One-Way signalling

With one-way signalling, each eNodeB exchanges the signaling related with resource allocation to its neighbor cells. Each eNodeB makes the scheduling decision by itself according to the exchanged information from its neighbor cells. It should be noted that the one-way signalling only applies to the distributed architecture.

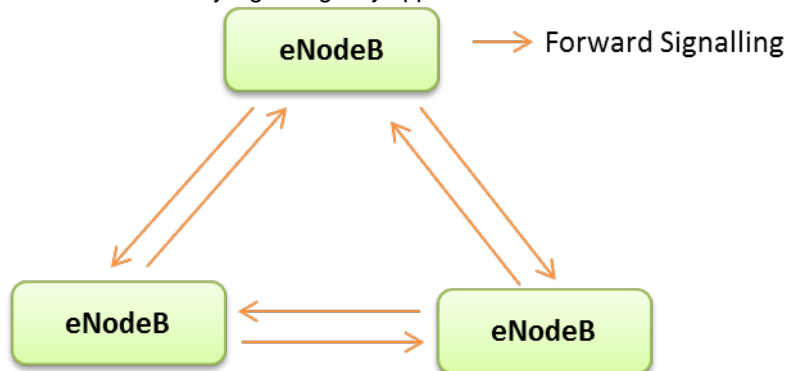

Figure 34 One Way Signalling for CoMP

4.2.2 Two-Way Signalling

The two-way signalling could be applied to both distributed and centralized architecture. In the distributed architecture, each eNodeB reports the CSI-related information to its neighbor eNodeBs. Each eNodeB makes the scheduling decision and then returns the scheduling decision to each eNodeB.

In the centralized architecture, each eNodeB reports CSI-related information to the centralized resource coordinator. The centralized RC makes the scheduling decision and then sends back to each eNodeB.

The reported CSI-related information could be raw CSI (e.g., CQI, RSRP) or benefit metrics derived from raw CSI, depending on the backhaul throughput and the scheduling algorithm.

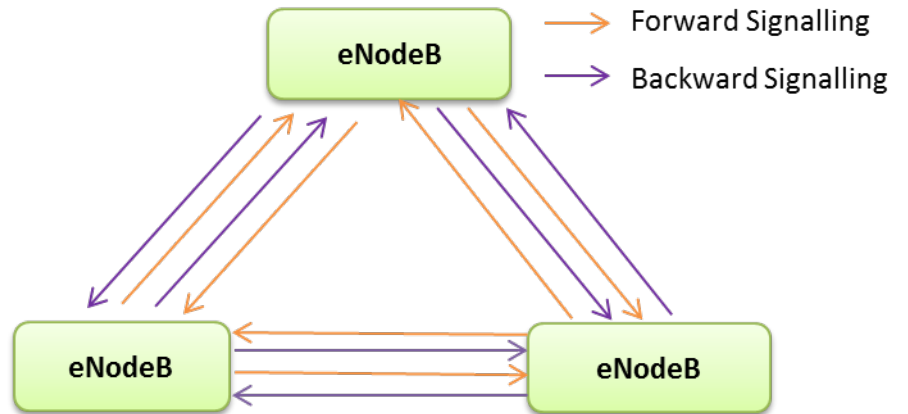

(a) Two-way signalling for distributed architecture

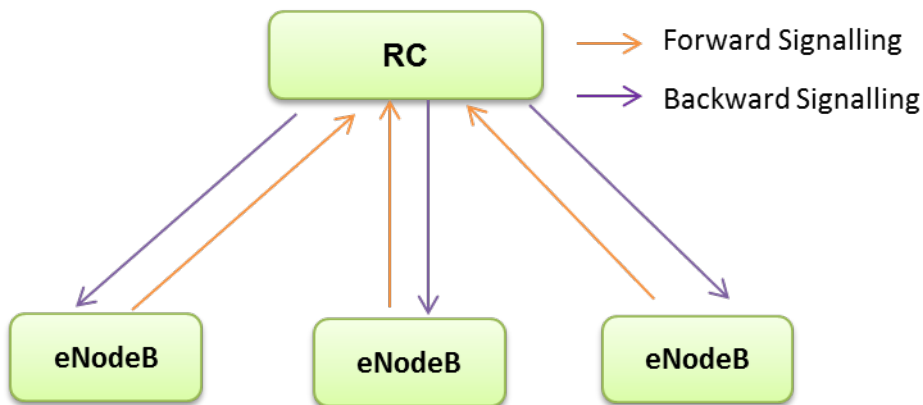

(b) Two-way signalling for centralized architecture

Figure 35 Two-way signalling for CoMP

For the above two-way signalling, the coordination result is made by the resource coordinator or the neighbor eNodeBs. It's possible that the individual scheduler of the eNodeB does not follow the scheduling results but makes decision by itself. Therefore, it's preferred that the receiving eNodeB should send back a response, e.g., yes or no, to the sending coordinator.

4.3 Possible solutions for CoMP with NIB

The performance of CoMP with NIB largely depends on the algorithm. In this contribution, two solutions are discussed in order to make comparisons.

4.3.1 Study case 1: CSI exchan

Figure 36 shows the logical procedure of signaling exchange for CS in non-ideal backhaul. The resource coordinator (RC) in Figure 36 is in charge of coordinated scheduling for multiple eNBs. Even the RC is depicted as a network entity separated from eNB, but it can be merged into eNB as a software function block. The CoMP operational flows in Figure 36 are expressed as follows.

- 1) eNBs transfer the CSI received from UEs to RC.
- 2) RC performs inter-eNB coordination based on shared CSI.
- 3) RC sends the coordinated resource information (CRI) to eNBs

- 4) All eNBs perform UE scheduling based on the CRI received from RC and CSI available at individual eNBs.

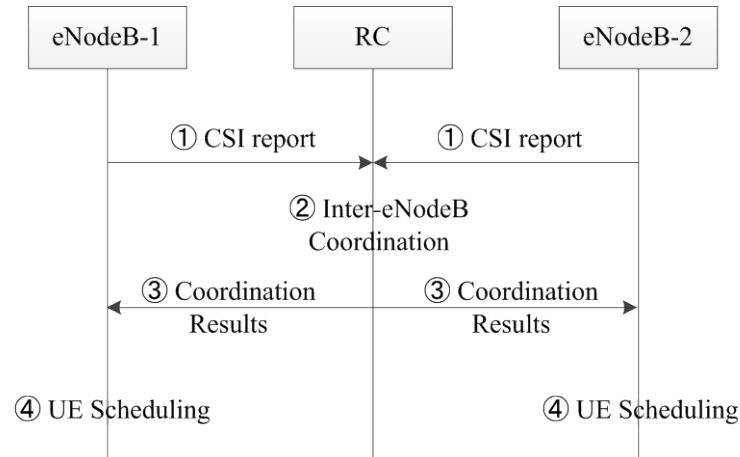

Figure 36. CoMP CS signaling message flow in non-ideal backhaul environments

In the above scheme, the UE-specific raw CSI information together with other information (e.g., RSRP, UE throughput) is reported to the RC for coordination. The signalling provides enough information but requires much backhaul capacity.

4.3.2 Study case 2: Autonomous Muting

Autonomous muting is a CoMP scheme which could fit both centralized architecture and distributed architecture. Figure 37 (a) shows the signaling flow for autonomous muting in the distributed architecture under non-ideal backhaul assumption with the following major steps:

- 1) Each eNodeB calculates the benefit metric (BM) based on UE's raw CSI report and other information, such as, UE's average throughput, buffer status, QoS. Benefit metric is cell-specific information, and it is more flexible for reality deployment taking into account mix traffic.
- 2) Each eNodeB exchanges the benefit metric information with neighbors. Under non-ideal backhaul, eNB may use fresh Benefit Metric from own cells and outdated BM from other eNBs.
- 3) Each eNB can decide its own muting pattern with the benefit metric information from all neighbors.
 - a. The basic principle is that the sum of the benefit metrics from a given cell's neighbors should be larger than the penalty of the given cell's muting.
 - b. Since the benefit metric is derived by the UE reported CSI, the freshness of benefit metric is important. In typical Macro deployment, one eNB has multiple co-located sectors. Thus eNB can obtain "fresh" benefit metric, based on fresh CSI report, from its own cells (co-located) and "outdated" benefit metric from neighbor eNB (backhaul latency applies). In addition, in the distributed architecture the penalty of a given cell's muting is also "fresh," unlike in the centralized architecture where even the penalty information is affected by the backhaul latency.
- 4) The eNBs shall exchange its muting decision to all neighbors to help scheduling and link adaptation. The muting decision could be exchanged in the form of enhanced RNTP message.
- 5) Each eNodeB makes UE scheduling according the muting decisions from the neighbor cells.

The above solution could also be applied to the centralized architecture, where each eNodeB reports the benefit metric to the resource coordinator, and the resource coordinator makes the muting decision and returns to each eNodeB, as is shown in Figure 37 (b).

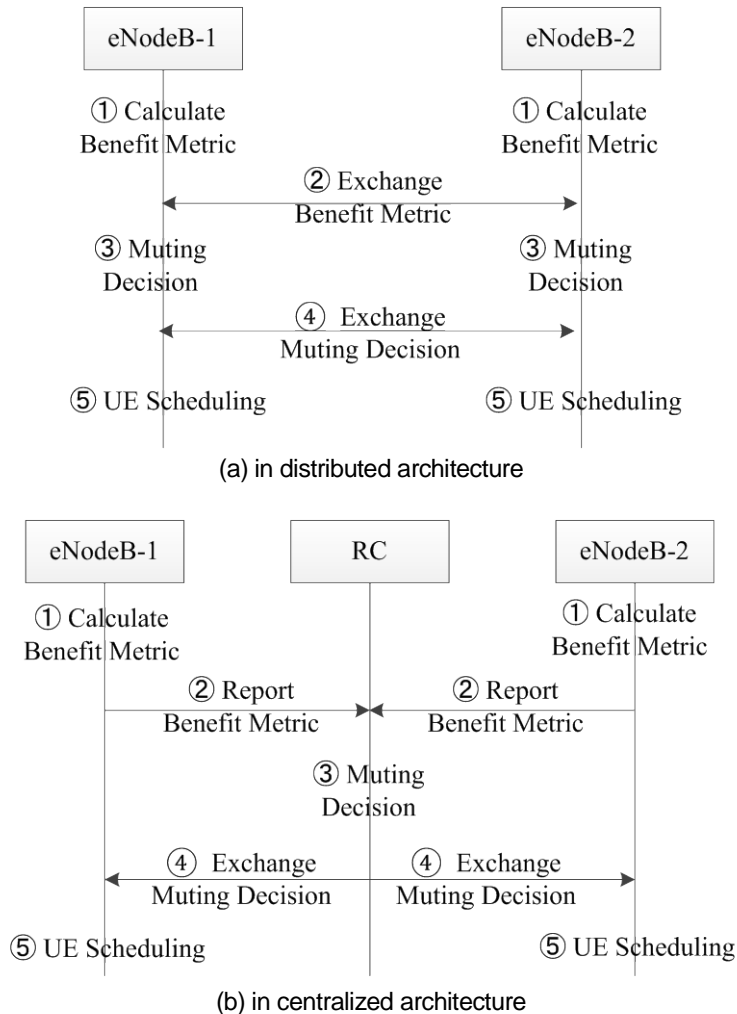

Figure 37. Signaling flow of autonomous muting

The major difference between case 1 and case 2 lies in that case 1 exchange UE-specific signalling like raw CSI and UE scheduling results while case 2 exchanges cell-specific signalling like benefit metric and enhanced RNTTP. Generally, case 1 could provide more information for coordination but require more signalling throughput. Case 2 could reduce the signalling overhead but provide simplified information for coordination.

4.4 CoMP Architectural Analysis

In order to better understand the effectiveness of different architectures with different CoMP algorithms, some analysis is provided with comparisons concerning various aspects.

4.4.1 Time Synchronization

In CoMP JT, the cells participating in data transmission to UE should be synchronized in time. If these cells are not synchronized, the combining gain of JT may not be fully achieved. For CS, even a single point or cell in CoMP cooperating set is the CoMP transmission point [1]. Nevertheless, time synchronization for the cells included in CoMP cooperating set is required still. If not synchronized, the cells within the CoMP cooperating set may not allocate higher modulation and coding scheme (MCS).

As mentioned before, the latency of non-ideal backhaul is larger than that of ideal backhaul, so every eNB may have different backhaul latencies. As shown in Figure 38, even the CRI sent from RC at the same time may arrive

at different time. Then, the CRI would not be applied at the same time, which would degrade the CoMP performance. For this issue, applying a time stamp can be a solution. The CRI would then carry a time stamp that denotes when the CRI should be applied. Then, based on the time stamp information, every eNB can identify the timing for applying the CRI, and detect the loss and late arrival of the CRI.

The SYNC protocol of evolved multimedia broadcast multicast service (eMBMS) [4] may be one of the solutions for time stamp. In eMBMS systems, the time stamp is generally set to Time Stamp value = time BM_SC receives the data packet + Max Tx Delay + synchronization sequence length + other extra delay. In the case of CoMP over non-ideal backhaul, this mechanism would be converted into as follows.

$$\text{Time Stamp value} \geq \text{time RC transmits CRI packet} + \text{maximum of (backhaul delay + jitter)} + \text{eNB processing time}.$$

The time stamp margin in Figure 38 denotes the difference between time stamp value and the time RC transmits the CRI message packets. If the RC in Figure 38 is replaced by master eNB or eNB in the other architectures, the same considerations as the centralized architecture can be derived. As it can be seen from Figure 38, the overall delay for transmission of CRI would be function of the latency and jitter of the worst performing eNB-RC backhaul link.

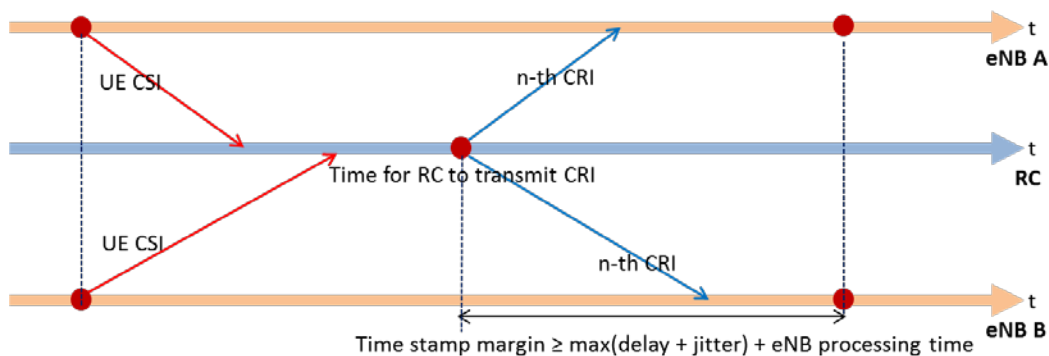

Figure 38. Time stamp margin for CoMP over non-ideal backhaul

4.4.2 Backhaul Latency

Since the signalling is exchanged via non-ideal backhaul, the latency is the key limitation of the CoMP performance. The backhaul latency largely depends on the network architecture.

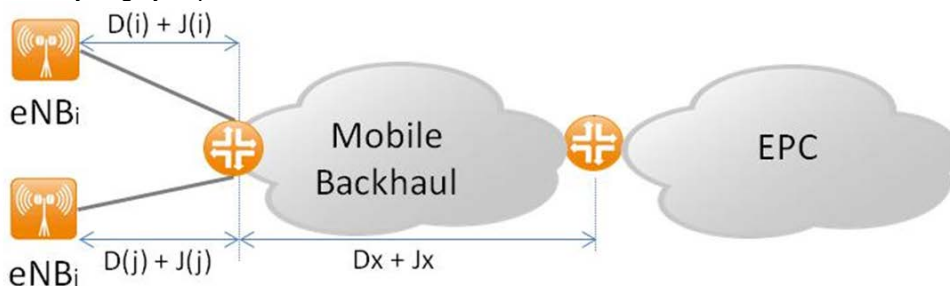

Figure 39. Reference model for backhaul network

For the centralized architecture, the backhaul latency is determined by the location of the resource coordinator. There are three possible locations for the RC:

1) The RC is located at the switch. Assuming that eNB processing time for CRI is equal for all eNBs and CRI is sent at the same time, let $D(i)$ and $J(i)$ denote the delay and jitter of backhaul link between i -th eNB and switch, respectively. Hereafter, the *maximum of (delay + jitter)* is called as CoMP backhaul latency for simplicity. The backhaul latency for this case could be denoted as

$$T_{BH} = \max_{i \in C_{cluster}} \{D(i) + J(i)\}$$

2) The RC is collocated with the S-GW/P-GW. In this case, the centralized RC is located in proximity to core network edge router. The RC could work for the largest coordination area to manage more eNodeBs but with larger latency. The backhaul latency needs to consider the delay from the switch to the S-GW. The additional latency and jitter between the local router and the centralized node is denoted as $D_x + J_x$. The backhaul latency for this case could be denoted as

$$T_{BH} = \max_{i \in C_{cluster}} \{D(i) + J(i)\} + D_x + J_x$$

3) The RC is located at certain eNodeB (Master-Slave mode). This is applicable in the Hetnet scenarios, where the macro eNodeB works as the resource coordinator for a cluster of small cells. In this case, the backhaul latency could be denoted as

$$T_{BH} = D(m) + J(m) + \max_{i \in C_{cluster}, i \neq m} \{D(i) + J(i)\}$$

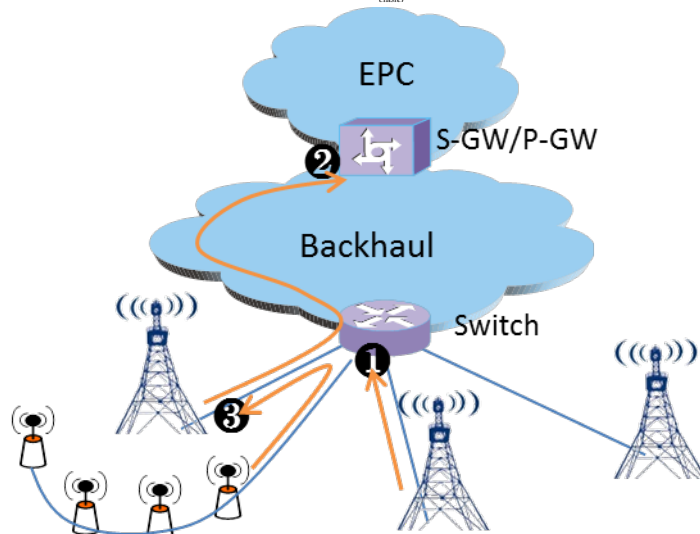

Figure 40 Possible locations of the resource coordination in the centralized architecture

For the distributed architecture, the signaling is exchanged logically via a peer to peer way. However, it should be noted that in some operators' transport network, the switch does not support L3 transfer currently. In such cases the signaling still needs to be exchanged through EPC. Therefore, there are two options for the signaling route for the distributed architecture.

1) The signalling is exchanged via the switch. In this case, the CRI sent by i -th eNB arrives at j -th eNB via one switch. Then, the CoMP backhaul latency of j -th eNB is expressed as follows.

$$T_{BH}(j) = D(j) + J(j) + \max_{i \in NBR_j, i \neq m} \{D(i) + J(i)\}$$

2) The signaling is exchanged via the router in the EPC side. It's noted that in some operators' transport network, the aggregation layer does not support L3 transfer currently. In such cases the signaling still needs to be exchanged through EPC unless support for L3 aggregation can be introduced. The backhaul latency is larger than the above case. The backhaul latency is denoted as

$$T_{BH}(j) = D(j) + J(j) + 2 * (D_x + J_x) + \max_{i \in NBR_j, i \neq m} \{D(i) + J(i)\}$$

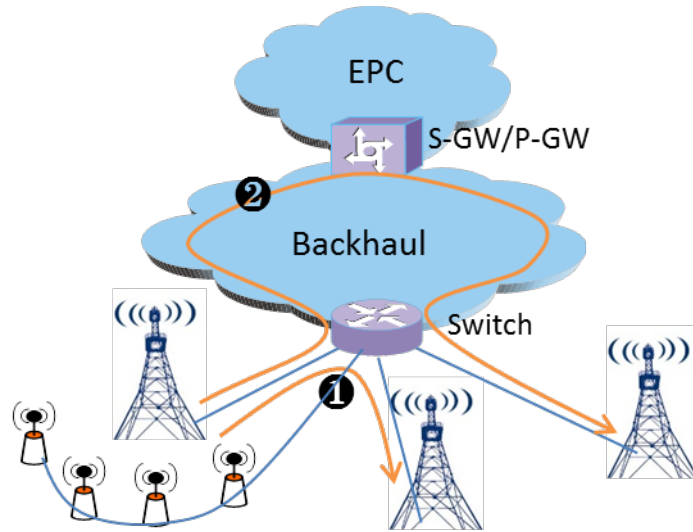
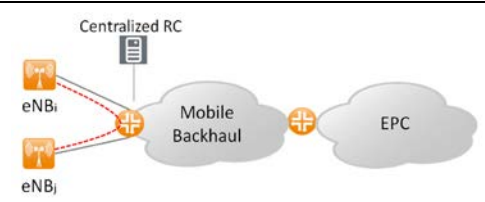
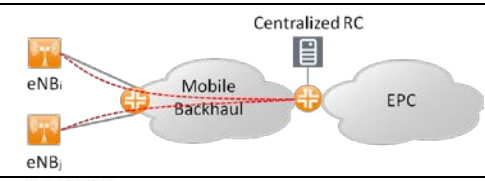
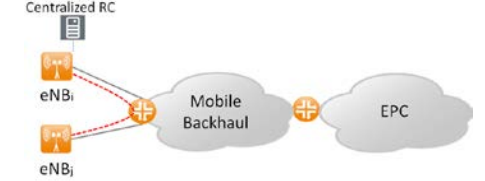

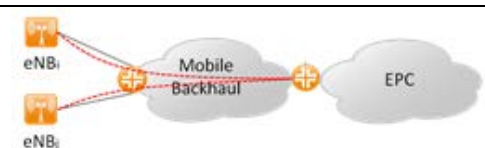

Figure 41 different signalling route in the distributed architecture

The CoMP backhaul latency for entire CoMP cluster is the maximum value of CoMP backhaul latencies of all eNBs within CoMP cluster. Otherwise, the CRI packets for eNB having the largest CoMP backhaul latency may arrive late frequently, and it may lead to reducing the CoMP gain. The CoMP backhaul latency for entire CoMP cluster is summarized in Table 7, where $C_{cluster}$ denotes the set of all eNBs within CoMP cluster. NBR_i is the set of neighbor eNBs of i -th eNB.

Table 7. CoMP backhaul latency for entire CoMP cluster

	CoMP Architecture	CoMP Backhaul Latency
Centralized		$\max_{i \in C_{cluster}} \{D(i) + J(i)\}$
		$\max_{i \in C_{cluster}} \{D(i) + J(i)\} + D_x + J_x$
		$D(m) + J(m) + \max_{i \in C_{cluster}, i \neq m} \{D(i) + J(i)\}$
Distributed		$\max_{j \in C_{cluster}} \left[D(j) + J(j) + \max_{i \in NBR_j, i \neq m} \{D(i) + J(i)\} \right]$
		$\max_{j \in C_{cluster}} \left[D(j) + J(j) + 2 * (D_x + J_x) + \max_{i \in NBR_j, i \neq m} \{D(i) + J(i)\} \right]$

--	--	--

4.4.3 Backhaul Bandwidth

Figure 42 illustrates signaling messages exchanged in CoMP architectural options.

- In the study case 1 for the centralized CoMP architecture, each eNB transfers the CSI of its own UEs to the resource coordinator. The transferred CSI contains the CSI of cell-edge UEs and/or cell-center UEs. Then the RC replies to the eNB with a group of CRI. The group of CRI contains CRI of the target eNB and its neighbor eNBs. This method requires a considerable amount of backhaul capacity.
- In the study case 2 for the distributed CoMP architecture, each eNodeB needs to exchange signalling with several neighbor cells. The backhaul may not be able to support large capacity of signalling information such as raw CSI of all UEs or even of the cell edge UEs. Therefore, a cell-specific benefit metric derived from CSI-related information may be an alternative. Each eNB sends the benefit metric to the neighbor eNBs and then the neighbor eNB replies to the eNB with own CRI.

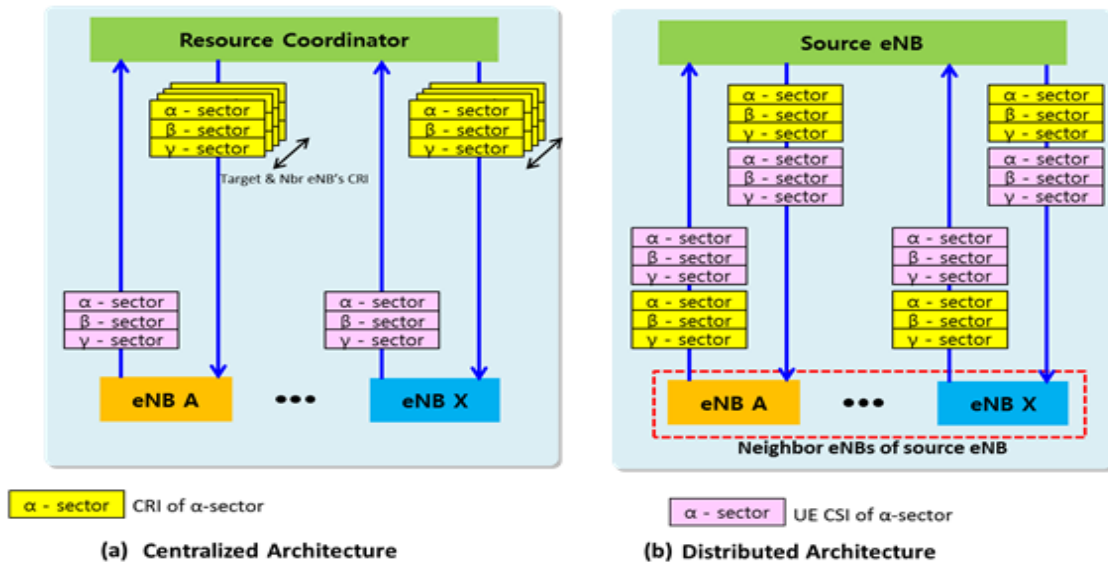

Figure 42. CoMP signaling exchange in CoMP architectures

In the centralized CoMP architecture, each eNodeB sends its own UEs' CSI to the resource coordinator and the RC returns the CRI to the individual eNodeB, so the transmission rate per cell is expressed as the following:

$$\alpha * Tx \text{ rate of CSI} + Tx \text{ rate of CRI}$$

where α denotes the ratio of UEs that are reported on (maybe restricted to cell edge UEs). On the additional assumption of 3-sectored eNB, the required bandwidth per eNB for CoMP is expressed as follows.

$$3 * (\alpha * Tx \text{ rate of CSI} + Tx \text{ rate of CRI})$$

Accordingly, the required bandwidth of the whole CoMP cluster could be denoted as:

$$\# \text{ of eNBs} * 3 * (\alpha * Tx \text{ rate of CSI} + Tx \text{ rate of CRI})$$

If the cell-specific benefit metric (BM) and the muting decision (MD) is exchanged, the transmission data rate per cell is expressed as:

$$Tx \text{ rate of BM} + Tx \text{ rate of MD}$$

It's noted that the signalling overhead is significantly reduced with the cell-specific information.

In the distributed CoMP architecture, if the UE-specific CSI information is exchanged between eNodeBs, the required backhaul throughput could be denoted as:

$$\# \text{ of neighbor eNBs} \cdot \# \text{ of cell under each eNB} \cdot (\alpha \cdot \text{Tx rate of CSI} + \text{Tx rate of CRI}),$$

The required backhaul throughput is linearly increased with the number of neighbor eNBs, which will impose considerable pressure on the backhaul. Therefore, it maybe preferred that only benefit metric information is transmitted in distributed CoMP architecture due to the limitation of backhaul throughput. The transmission rate per cell should then be as follows:

$$\# \text{ of neighbor eNBs} \cdot \# \text{ of cell under each eNB} \cdot (\text{Tx rate of BM} + \text{Tx rate of MD}),$$

If bi-directional neighbor relation is assumed, the arrival rate is the same as the transmission rate. On the additional assumption of 3-sectored eNB, the required bandwidth per eNB for CoMP is expressed as follows:

$$3 \cdot 2 \cdot \# \text{ of neighbor eNBs} \cdot (\text{Tx rate of BM} + \text{Tx rate of MD})$$

For simple analysis, assuming that each eNB has equal number of neighbor eNBs, the required total bandwidth in entire CoMP cluster for the distributed architecture is expressed as follows.

$$\# \text{ of eNBs} \cdot 3 \cdot \# \text{ of neighbor eNBs} \cdot (\text{Tx rate of BM} + \text{Tx rate of MD}).$$

It reaches the equations in Table 8 to adopt the same analysis method as the distributed CoMP architecture into the master/ slave and centralized CoMP architecture. Note that the number of neighbor eNBs in master/ slave and centralized CoMP architecture is different from that of distributed architecture. The number of neighbor eNBs in distributed architecture denotes the number of neighbor eNBs included in MR of cell edge UEs, and is generally smaller than that of the other architectures. In Table 8, it is expressed as the number of interfering neighbor eNBs.

Table 8. Additional required backhaul bandwidth in CoMP architectures

Case	CoMP Architecture	Signaling exchange	Required Backhaul Bandwidth
Bottleneck eNB	Centralized	UE-specific information	$3R_{CSI} \cdot N_{UE} + 3R_{CRI}$
		Cell-specific information	$3R_{BM} + 3R_{MD}$
	Distributed	UE-specific information	$6N_{NBR}^* \cdot (R_{CSI} \cdot N_{UE} + R_{CRI})$
		Cell-specific information	$6N_{NBR}^* \cdot (R_{BM} + R_{CRI})$
Entire CoMP Cluster	Centralized	UE-specific information	$3N_{eNB} \cdot (R_{CSI} \cdot N_{UE} + R_{CRI})$
		Cell-specific information	$3N_{eNB} \cdot (R_{BM} + R_{MD})$
	Distributed	UE-specific information	$3N_{eNB} \cdot N_{NBR}^* \cdot (R_{CSI} \cdot N_{UE} + R_{CRI})$
		Cell-specific information	$3N_{eNB} \cdot N_{NBR}^* \cdot (R_{BM} + R_{CRI})$

- R_{CSI} : transmission rate of CSI of all UE
 R_{CRI} : transmission rate of CRI of cell
 R_{BM} : transmission rate of benefit metric of cell
 R_{MD} : transmission rate of muting decision of cell
 N_{eNB} : # of eNBs within CoMP cluster
 N_{NBR} : # of neighbor eNBs
 N_{NBR}^* : # of interfering neighbor eNBs, $N_{NBR}^* \leq N_{NBR}$
 N_{UE} : # of UE in one cell

It is concluded that the backhaul bandwidth requirement from different architecture varies according to number of user in one cell and size of the coordination area, etc.

4.5 Performance evaluation

A number of different simulation results exist on the performance benefits of CoMP over non-ideal backhaul using different approaches.

The performance evaluation of 3GPP and companies are provided in Appendix 2. These supplement the field trial results provided in section 2.2.1.

4.6 Concluding Remarks

The following observations are provided concerning the implementation of CoMP when adopted in RAN with non-ideal backhaul:

- In order to support both centralized and distributed CoMP architecture, two-way signalling is required.
- The UE-specific raw CSI information could provide more information for coordination but require more signalling throughput. The cell-specific benefit metric could reduce the signalling overhead but provide simplified information for coordination.
- The intra-vendor CoMP could be implemented by each individual vendor while inter-vendor CoMP requires standardization of the exchanged signalling via X2 or other interface.

4.7 Operators' view on CoMP with non-ideal backhaul

In order to investigate the operators' view on CoMP with non-ideal backhaul, an anonymous survey was initiated among the operators in NGMN. The survey results were concluded as follows:

- A clear majority of NGMN operators expects that 3GPP will continue the WI of CoMP-NIB and try to complete the standardization of CoMP-NIB in Release 12.
- The standardization of centralized implementation for CoMP-NIB has the support of nearly half of the operators while most of the others are still undecided.
- 3GPP can consider converged signalling supporting both centralized and distributed coordination. Signalling of raw measurement information (CSI, RSRP) to the coordinator is recommended, at least for the centralized case.

5 CHALLENGES AND CONSIDERATIONS OF CoMP

According to the feedbacks of CoMP trials, the following challenges should be further considered, and some general requirements of CoMP commercialized are given.

5.1 Challenges of CoMP implementation

The variety of different CoMP schemes and the different methods used for their evaluation risk a fragmentation of requirement and implementations. It is therefore beneficial for operators to identify jointly the most beneficial methods and ensure any necessary terminal functions are standardized and implemented in a timely way.

Different CoMP methods have differing, and in some cases challenging impacts on the transport network. In particular, JT requires high bandwidth and low delay in the fronthaul network, which is typically expected to be typically provided by fibre connections, The lack of high performance fibre transport in many networks is likely to limit the inter-site application of some CoMP methods, and for this reason it is important to consider also non-ideal backhaul CoMP methods to address inter-site interference.

CoMP schemes are likely to impact the architecture of mobile networks. Inter-site JT and JP should both benefit from C-RAN deployments in which the baseband processing of multiple sites are concentrated at a central location in a DU-pool. For non-ideal backhaul with low latency (e.g. 5~15ms), coordinated scheduling may benefit from coordinating the scheduling (distributed or centralized) of different cells. The introduction of centralized nodes for LTE might further be exploited in other Multi-RAN cooperation methods.

Another consideration for certain types of CoMP is the need to support time synchronization between cells. Coherent joint transmission will require strict requirements on the accuracy of time synchronization that necessitate the support of accurate timing synchronisation over the backhaul. Other forms of CoMP such a coordinated scheduling also require time synchronization, but with less strict timing accuracy.

5.2 Requirements of CoMP commercialization

Commercial deployment of CoMP will require the following:

- (1) Due to the long term co-existence of different generations of Ues, the proposed CoMP schemes must be backward-compatible in supporting operation in a network containing older Ues
- (2) It is very desirable that the CoMP schemes utilize R8 functionality already supported in phones, in order to support operation of the CoMP scheme in legacy terminals and, where appropriate, avoid unnecessary overheads.
- (3) Due to different transport capabilities available to different network, CoMP schemes should be considered both for ideal backhaul (i.e. C-RAN deployment) and non-ideal backhaul.

Table 9 Summary of the requirements of different CoMP schemes

CoMP Architecture and Schemes		Requirements	FrontHaul Throughput (Mbps/cell)	One way Latency (ms)
C-RAN	CoMP with ideal FH (Without compression)	2/8 antenna	2458/9830	~250us
CoMP Architecture and Schemes		Requirements	BackHaul Throughput (Mbps/cell)	Latency (ms)
D-RAN (non-ideal BH)	Centralized CS		5~10	4~15ms
	Distributed CS		5~10	4~15ms

	Downlink CoMP	Coordinated BF	<10	~4ms
		Non-Coherent JT	15~20	~4ms
Time synchronization requirement in FDD is the same as the one in TDD				

6 CONCLUSION

- C1: Severe interference in current networks
 - The field trial results show significant inter-cell interference in LTE networks which leads to severe decrease in cell-average throughput. Therefore, technologies to reduce inter-cell interference are in urgent demand.
- C2: CoMP can reduce inter-cell interference efficiently
 - The CoMP technology could reduce the inter-cell interference and improve the both cell-edge and cell-average throughput. The performance gain depends on the CoMP scheme and the deployment environment.
- C3: Need to be implemented in R8/9/10 network
 - Due to the long term co-existence of different generations of Ues, the proposed CoMP schemes must be backward-compatible in supporting operation in a network containing legacy Ues.
 - It is very desirable that the CoMP schemes utilize R8/9/10 functionality already supported in phones, in order to support operation of the CoMP scheme in legacy terminals and, where appropriate, avoid unnecessary overheads.
- C4: Consider both ideal backhaul and non-ideal backhaul
 - Due to different transport capabilities available to different network, it would be beneficial if CoMP schemes could be considered both for ideal backhaul (i.e. C-RAN deployment) and non-ideal backhaul.

APPENDIX

APPENDIX I SIMULATION PARAMETER FOR C-RAN EVALUATION

Carrier frequency	2.0 GHz
Duplex	FDD
Scenario	Configuration „4b“ according to 3GPP 36.814
Layout	Regular hexagonal with 7 sites and 3 sectors per site, wrap around
Inter site distance	500 m
Backhaul	Zero latency, infinite bandwidth
Pico cells randomly positioned in macro call coverage	

Distance-dependent pathloss	According to 3GPP 36.814 „Model 1“ including frequency correction
Outdoor to indoor building penetration loss	20 dB (all mobiles indoor)
Outdoor to in-car penetration loss	n.a.
Lognormal Shadowing Correlation	0.5 intersite; 1 intra site
Shadowing Standard deviation	8 dB
Fast Fading Model	Macro: 3GPP Case1; SCM; NLOS Pico: ITU-R UMi; NLOS

Macro Cell parameters

Sector configuration	Tri-sectorized
Height	32 m
Max. Tx Power	46 dBm
Noise Figure	5 dB
Number of antennas	2 for pico, 2 or 4 for macro, $0.5 \cdot \lambda$ spacing
Antenna configuration	Cross-polarized
Antenna pattern	3D antenna pattern according to 3GPP 36.814
Antenna gain	14 dBi
Horizontal Pattern	70° 3dB width, 25dB backward attenuation
Vertical Pattern	10° 3dB width, 20dB backward attenuation
Downtilt	15°

Pico Cell parameters

Sector configuration	Single-sectorized
Height	5 m
Max. Tx Power	30 dBm
Noise Figure	5 dB
Number of antennas	2, 0.5*lambda spacing
Bias	6 dB
Antenna configuration	vertical
Antenna pattern	Omni
Antenna gain	5 dBi
Horizontal Pattern	n.a.
Vertical Pattern	n.a.
Downtilt	n.a.

Scheduler	Proportional fair, frequency selective (Maximum Priority Envelope), mobile scheduled by its serving sector (no cooperative scheduling)
Traffic model	Non-Full Buffer, File-size=0.5MBytes; T_drop=8sec
Max. number of scheduled mobiles per TTI and sector	10
Bandwidth	10 MHz
Reuse scheme	1
Number of resources	50
Number of signaling overhead resources	4
Number of sounding symbols per resource	1
Number of pilot symbols per resource	2
Link adaptation	Real link adaptation with 5TTI (5ms) delay and 10% target BLER
Modulation formats	QPSK, 16 QAM, 64 QAM

APPENDIX II: PERFORMANCE EVALUATION IN DIFFERENT COMP ARCHITECTURES

The evaluation of the performance of CoMP with non-ideal backhaul has been done by many companies. The evaluation results largely depend on the evaluation model and CoMP algorithm. In this appendix, different evaluations are collected for reference.

A2.1 Evaluation results of CoMP with non-ideal backhaul by 3GPP

TR36.874 [12] has captured CoMP performance of each contribution in type of scatter plots and summarized as median value of mean UPT and 5% UPT for each scenarios.

- Scatter plots for performance under CoMP scenario 2 (macro cellular), SCE scenario 1 (hetnet, co-channel macro & small cells), and SCE scenario 2a (hetnet, dedicated frequency for small cells) in case of 5ms backhaul delay and high RU are provided in Figure 43, Figure 44, and Figure 45, respectively.
- Scatter plots for performance under CoMP scenario 2, SCE scenario 1, and SCE scenario 2a in case of 50ms backhaul delay and high RU are provided in Figure 46, Figure 47, and Figure 48, respectively.

It was observed that CoMP-NIB gain varies as a factor of deployment scenario, backhaul delay, coordination scheme, resource utilization factor, and coordination size.

- In case of 5ms backhaul delay and high RU
 - For CoMP scenario 2 with coordination size of 9, it is observed that
 - Mean UPT gain has a median of -4.7%
 - 5% UPT gain has a median of -3.2%
 - For CoMP scenario 2 with coordination size of 21, it is observed that
 - Mean UPT gain has a median of -5.2%
 - 5% UPT gain has a median of 0.5%
 - For SCE scenario 1 in case of 4 small cells within one macro area, it is observed that
 - Mean UPT gain has a median of 6.1%
 - 5% UPT gain has a median of 11.4%
 - For SCE scenario 1 in case of 10 small cells within one macro area, it is observed that
 - Mean UPT gain has a median of 1.4%
 - 5% UPT gain has a median of 16.4%
 - For SCE scenario 2a in case of 4 small cells within one macro area, it is observed that
 - Mean UPT gain has a median of 5.1%
 - 5% UPT gain has a median of 6.8%
 - For SCE scenario 2a in case of 10 small cells within one macro area, it is observed that
 - Mean UPT gain has a median of 22.9%
 - 5% UPT gain has a median of 11.7%
- In case of 50ms backhaul delay and high RU
 - For CoMP scenario 2 with coordination size of 9, it is observed that
 - Mean UPT gain has a median of -16.3%
 - 5% UPT gain has a median of -11.4%
 - For CoMP scenario 2 with coordination size of 21, it is observed that
 - Mean UPT gain has a median of -13.1%
 - 5% UPT gain has a median of -2.9%
 - For SCE scenario 1 in case of 4 small cells within one macro area, it is observed that
 - Mean UPT gain has a median of -0.5%

- 5% UPT gain has a median of 2.9%
- For SCE scenario 1 in case of 10 small cells within one macro area, it is observed that
 - Mean UPT gain has a median of -0.1%
 - 5% UPT gain has a median of -1.6%
- For SCE scenario 2a in case of 4 small cells within one macro area, it is observed that
 - Mean UPT gain has a median of -8.2%
 - 5% UPT gain has a median of -2.2%
- For SCE scenario 2a in case of 10 small cells within one macro area, it is observed that
 - Mean UPT gain has a median of -0.9%
 - 5% UPT gain has a median of 2.0%

In summary in CoMP scenario 2 for 9 cell coordination, inter-site CoMP does not provide significant gain over intra-site CoMP with 5ms backhaul latency, with median of -4.7% and range of -6.9 to 7%.

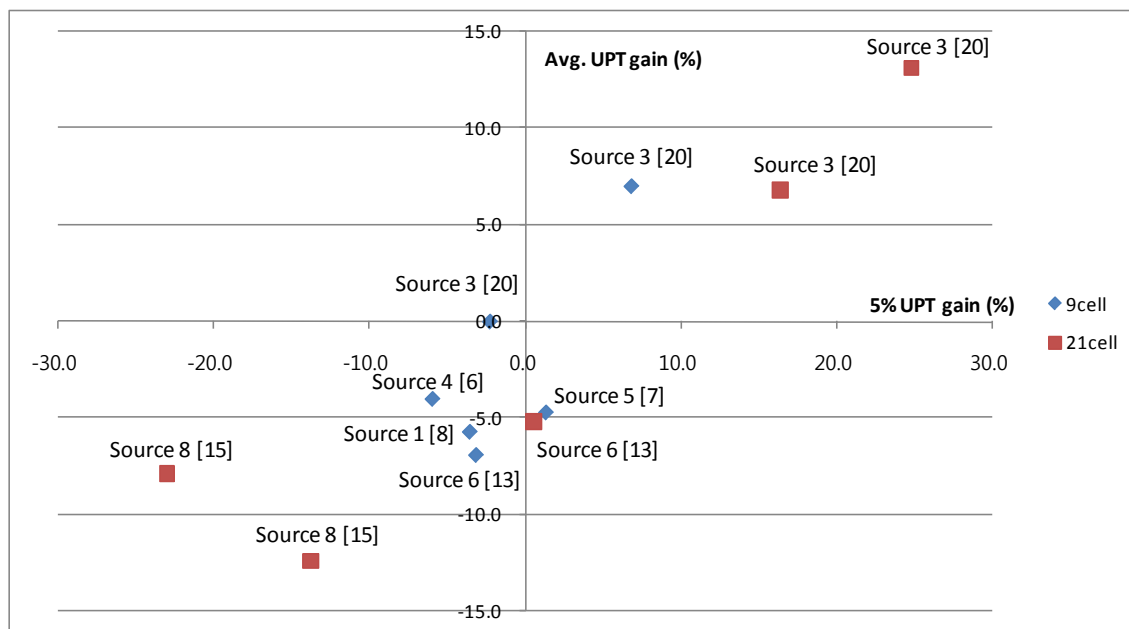

Figure 43 Scatter plot for performance under CoMP scenario 2 with NIB in case of 5ms backhaul delay and high RU (blue: 9-cell coordination, red: 21-cell coordination)

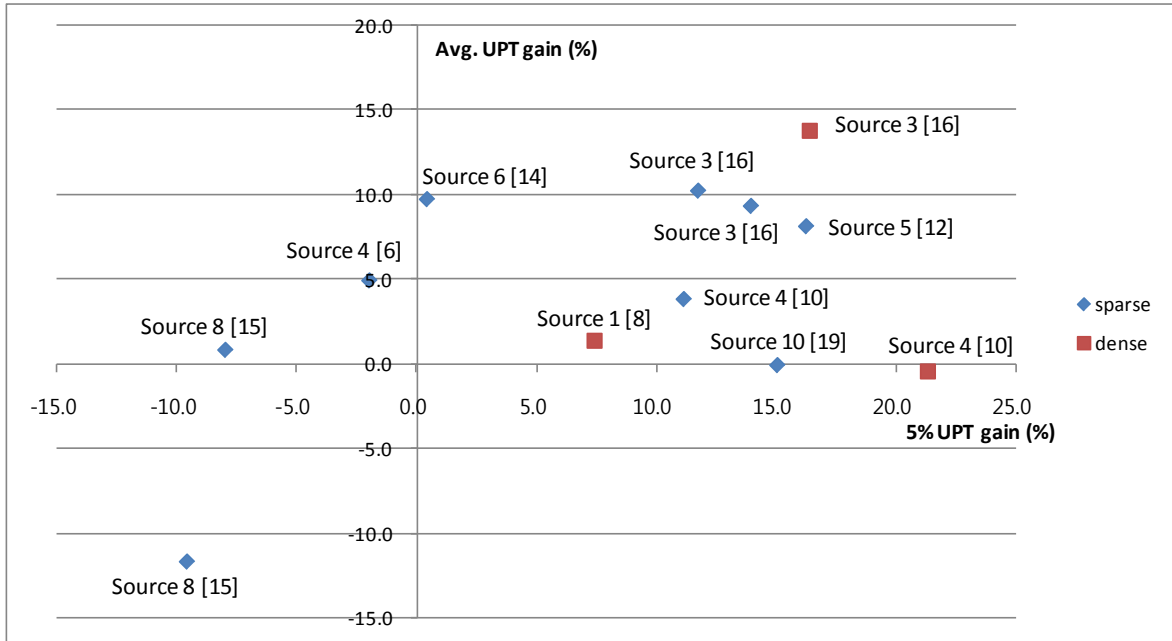

Figure 44 Scatter plot for performance under SCE scenario 1 with NIB in case of 5ms backhaul delay and high RU (blue: sparse deployment, red: dense deployment)

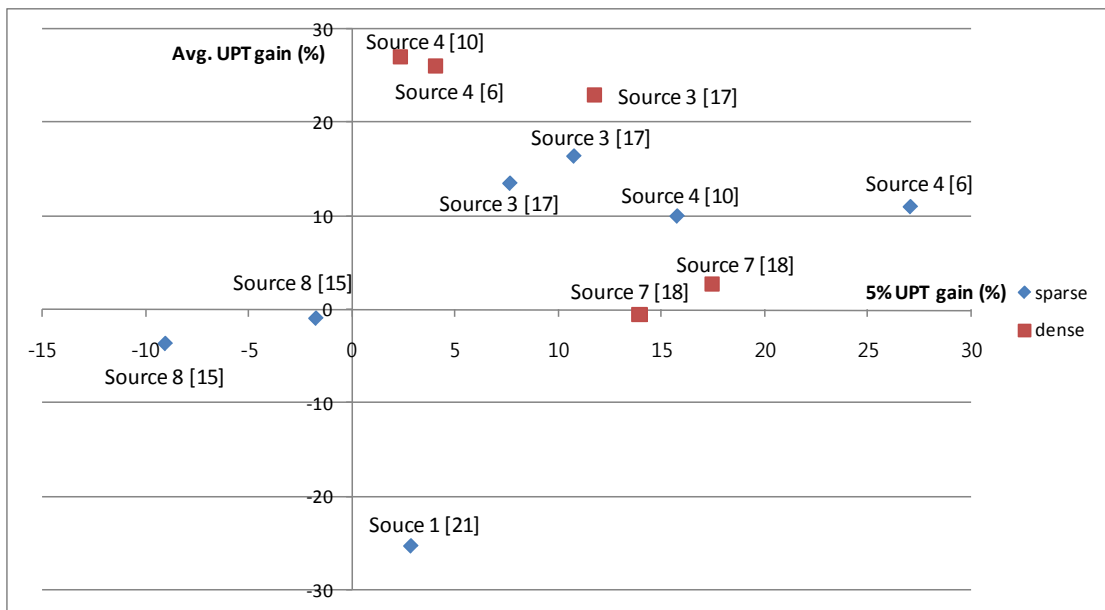

Figure 45 Scatter plot for performance under SCE scenario 2a with NIB in case of 5ms backhaul delay and high RU (blue: sparse deployment, red: dense deployment)

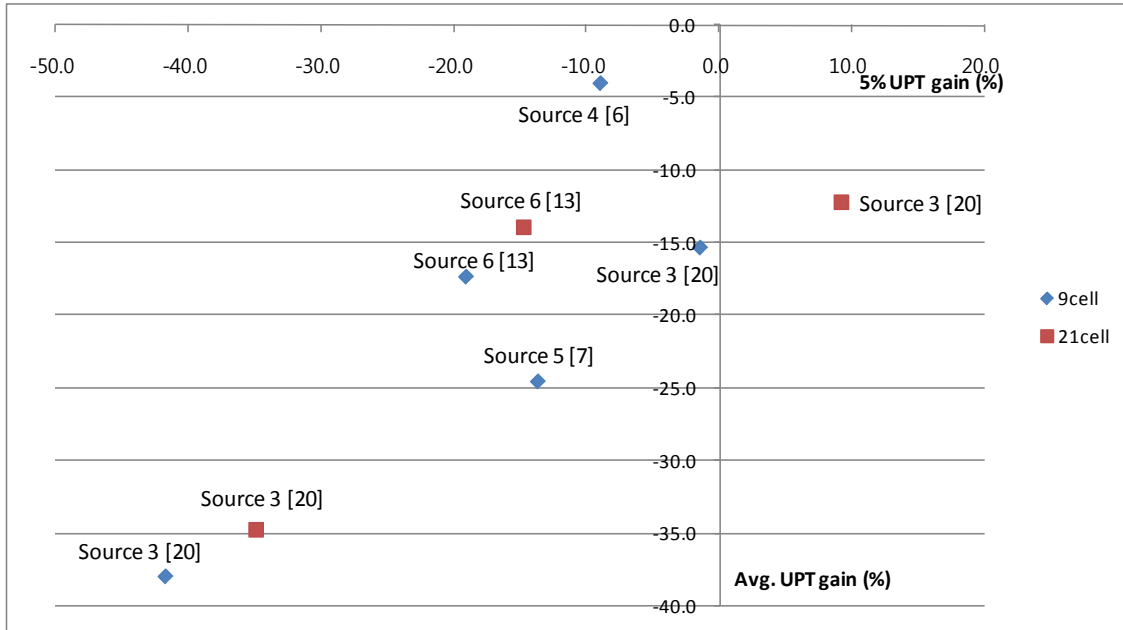

Figure 46 Scatter plot for performance under CoMP scenario 2 with NIB in case of 50ms backhaul delay and high RU (blue: 9-cell coordination, red: 21-cell coordination)

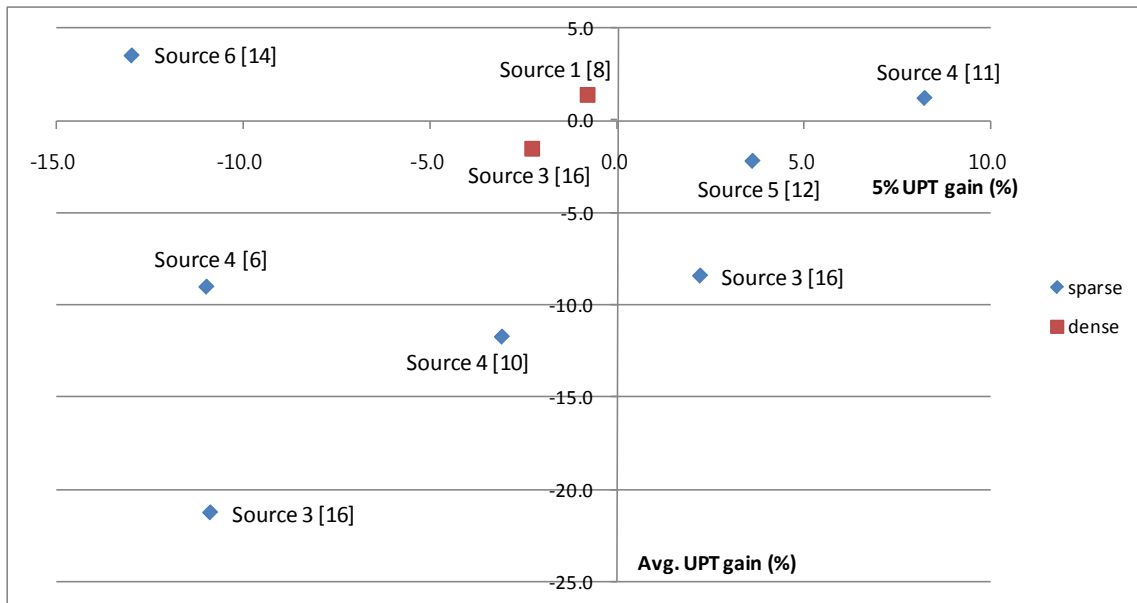

Figure 47 Scatter plot for performance under SCE scenario 1 with NIB in case of 50ms backhaul delay and high RU (blue: sparse deployment, red: dense deployment)

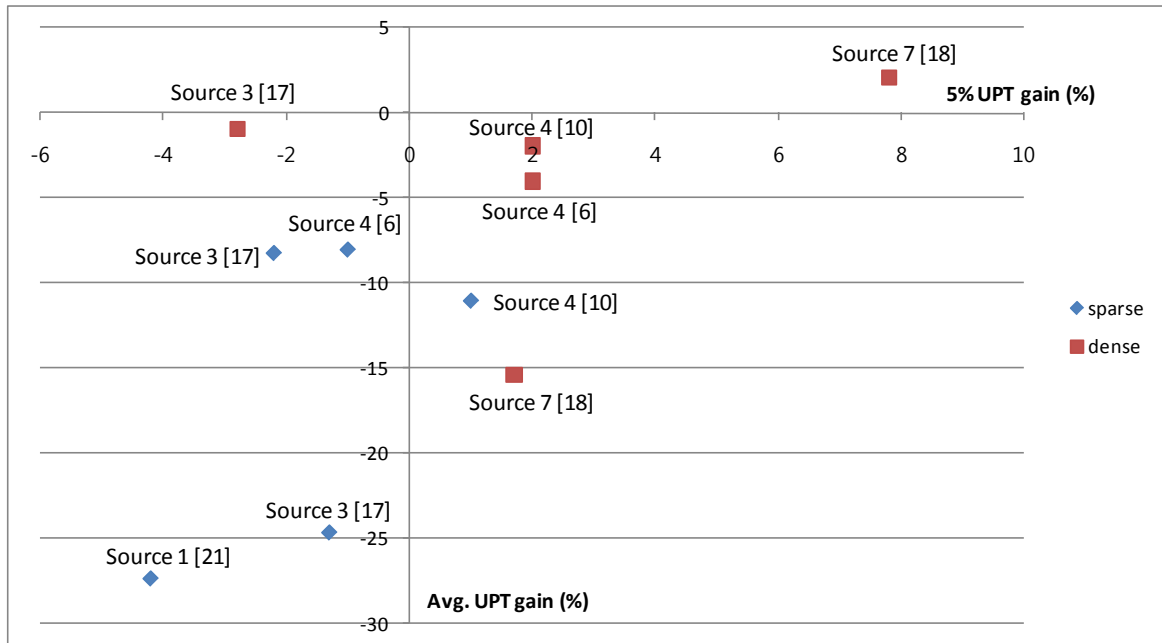

Figure 48 Scatter plot for performance under SCE scenario 2a with NIB in case of 50ms backhaul delay and high RU (blue: sparse deployment, red: dense deployment)

Observation:

- With 5ms backhaul delay, most of evaluations provide positive CoMP gain.
- With 50ms backhaul delay, most of evaluations provide negative CoMP gain.

A2.2 Comments on evaluation results of 3GPP

// Contributor: Ericsson

3GPP has performed an extensive simulation campaign to assess the performance of non-ideal backhaul CoMP as part of the study item ‘CoMP for LTE with non-ideal backhaul’. A key benefit of the 3GPP evaluations is that multiple companies contributed to the simulations since reported gains tend to depend on modelling assumptions in each company’s simulator. The conclusion section in [12] observes that.

It was observed that CoMP-NIB gain varies as a factor of deployment scenario, backhaul delay, coordination scheme, resource utilization factor, and coordination size.

and that median gains are as shown in Figure 49 and Figure 50.

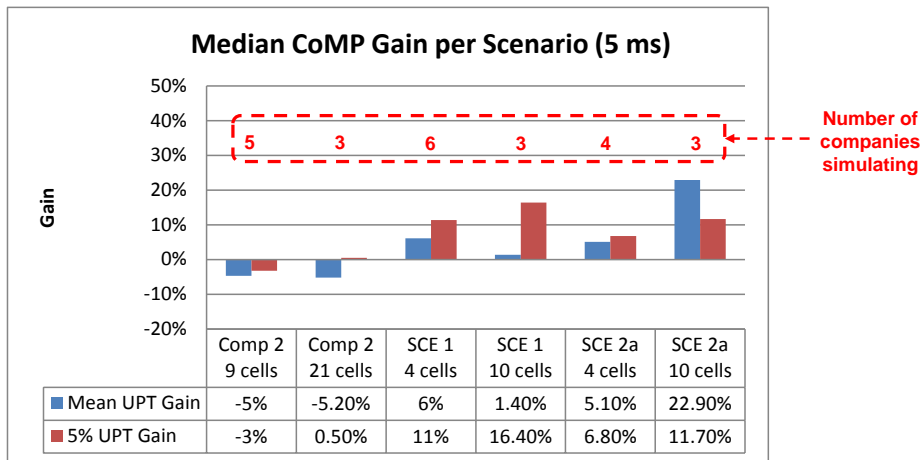

Figure 49. Median CoMP Gains for 5 ms backhaul latency case as reported in Section 7 of [12].

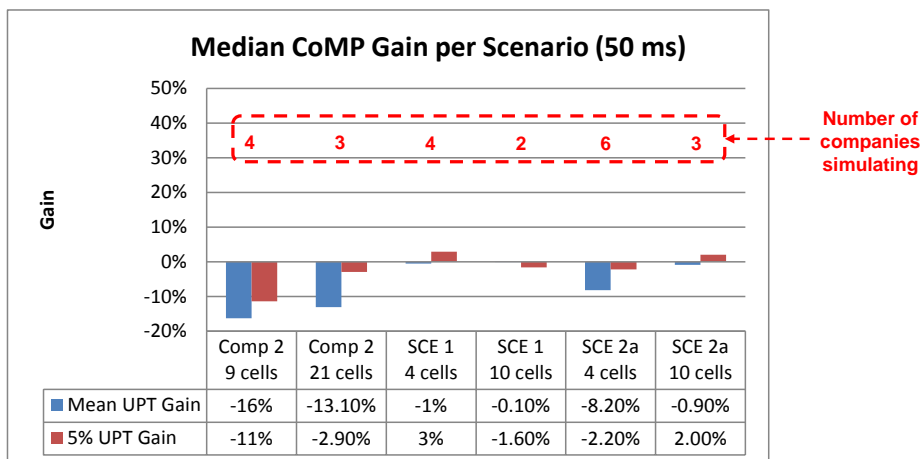

Figure 50. Median CoMP Gains for 50 ms backhaul latency case as reported in Section 7 of [12].

It should be noted that the main focus in the evaluations was not on the scenarios with ten small cells in a hotspot of radius 50 m, which represent scenarios that are computationally demanding to simulate. Thus only three companies simulated those cases and hence the gain numbers of those cases are expected to be more unreliable than for the other scenarios. In addition, there are indications that deploying ten small cells in a 50 m radius represents unnecessary densification and that performance of the non-CoMP reference scheme would be better if fewer small cells would have been deployed [R1-135659, “Evaluation Results for Different Small Cell ON/OFF Operational Modes”, Ericsson.].

The 3GPP evaluations further assumed infinite capacity on the backhaul and identical latency (e.g. 5 ms) between all links in the backhaul. This provides further indications that the reported gains in the 3GPP evaluations should be regarded as higher than what can be achieved in real-life. Also, the impact of CRS interference was in general ignored, which further helps in increasing the CoMP gains since the noise floor is not contaminated by CRS interference.

Observation

- 3GPP assumptions on traffic model, backhaul characteristics and lack of CRS interference modeling indicates that real-life CoMP gains are smaller than reported.

A2.3 Evaluation of centralized CoMP in a realistic environment

// Contributor: Samsung

3GPP has fulfilled performance evaluation for ‘CoMP for LTE with non-ideal backhaul’, as concluded in A1.1. However, 3GPP evaluation model is optimized to maximize individual cell’s spectral efficiency. In other words, CoMP gains are underestimated in 3GPP evaluation model. CoMP scenarios need to be evaluated under more realistic environment rather than 3GPP defined. 3GPP simulation parameters such as antenna tilt, handover margin and antenna pattern should be revised.

12 degree of antenna tilt is unrealistic, and down tilt is smaller in most deployments. Handover margin is larger than 1 dB in commercial operation to prevent ping-pong effect. 3D antenna pattern of 3GPP model would not reflect interference in the real field environments. In Table 6, modified parameters for realistic environments are summarized. The other parameters are followed according to Table A.1 CoMP Scenario 2 with NIB in [12]. In this subsection, any simulation parameters without notice are followed by the evaluation methodology described in [12].

Table 6. Modified parameters for performance evaluation in realistic environments

	3GPP Model	Realistic Environment
Antenna Tilt	12 degree	6 degree
Handover Margin	1 dB	3dB
Antenna Pattern	Ideal	Commercial (Katherein)

Figure 51 shows the simulation results of CoMP gains in realistic environments. Traffic loading and backhaul latency are assumed as 40% and 10ms, respectively. In Figure 28, CoMP gain increases under realistic environment and large coordination set size.

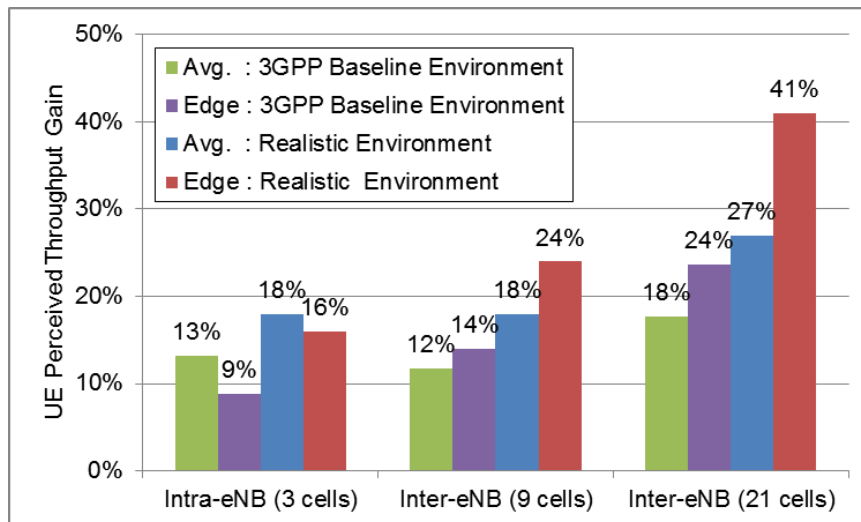

Figure 51. Comparison of CoMP gains between 3GPP model and realistic environment.

Figure 52 shows CoMP gains in different type of performance metric, which is the number of UEs satisfying QoS. Cell layout is 21 cells with 3-sectored antenna and 20 UEs are uniformly distributed per cell. For each UE, YouTube SD video traffic (500Kbps) is generated assuming 64Kbyte per chunk (YouTube traffic transmission unit) in throttling duration. Criteria for QoS satisfaction is assumed as receiving packets with packet drop rate less than 5%. The number of UEs satisfying QoS increases up to 81% in low SINR region (10.6 UEs → 19.2 UEs).

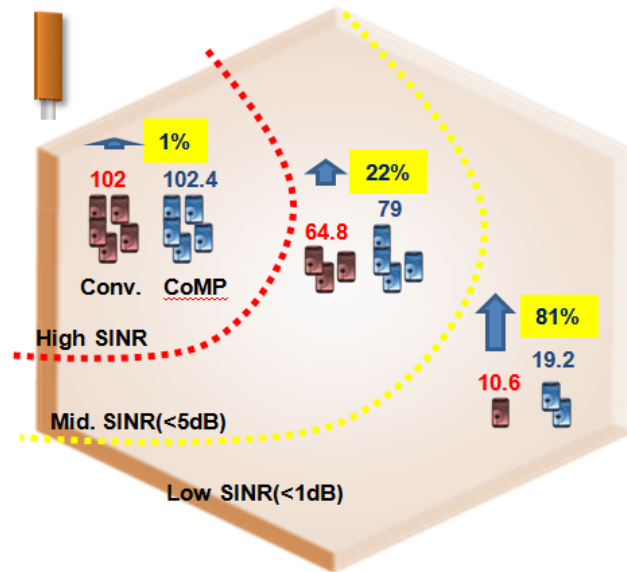

Figure 52. CoMP gain in realistic environment: number of UEs satisfying QoS

CoMP gain is additionally investigated in the following two scenarios: 1) full buffer scenario and 2) combined scenario with full buffer and non-full buffer. In scenario 1, 30 UEs with full buffer traffic are uniformly distributed in each cell. In scenario 2 case, there is difference between target cell and interfering cells in the point of number of UEs per cell and traffic model. 10 UEs with full buffer traffic are uniformly distributed in a target cell. 6 UEs with burst traffic are uniformly distributed in each interfering cell. Burst traffic is mixture of FTP2 traffic and ping with various size and interval. The CQI feedback and backhaul latency are assumed to be wideband CQI with 20ms period and 30ms RTT, respectively.

Figure 53 shows UE throughput gain of scenario 1. As the size of CoMP cluster increases, the throughput gain increases. Especially, the throughput gain of cell edge UE reaches up to 44% in 57 cells case.

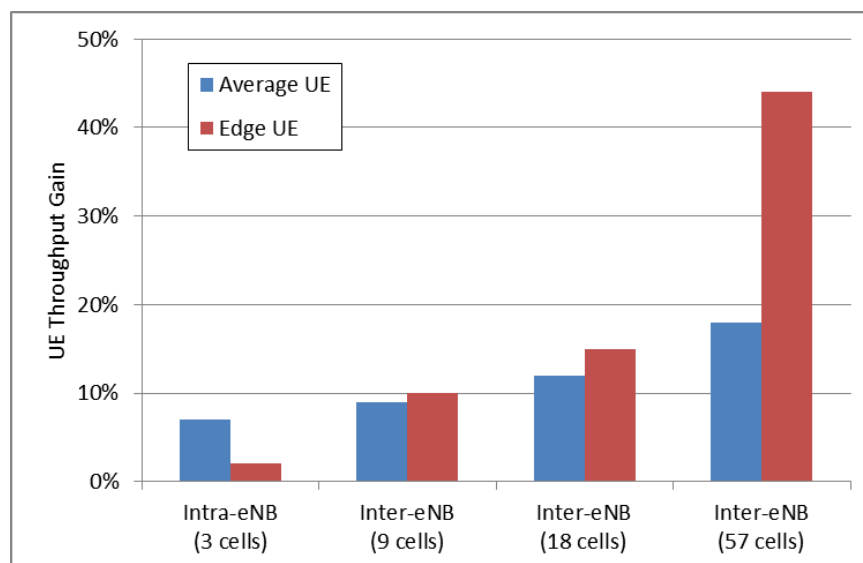

Figure 53. CoMP gain in realistic environment: Full buffer traffic model (Scenario 1)

In Figure 54, the throughput gain of cell edge UE reaches up to 80% in 57 cells case.

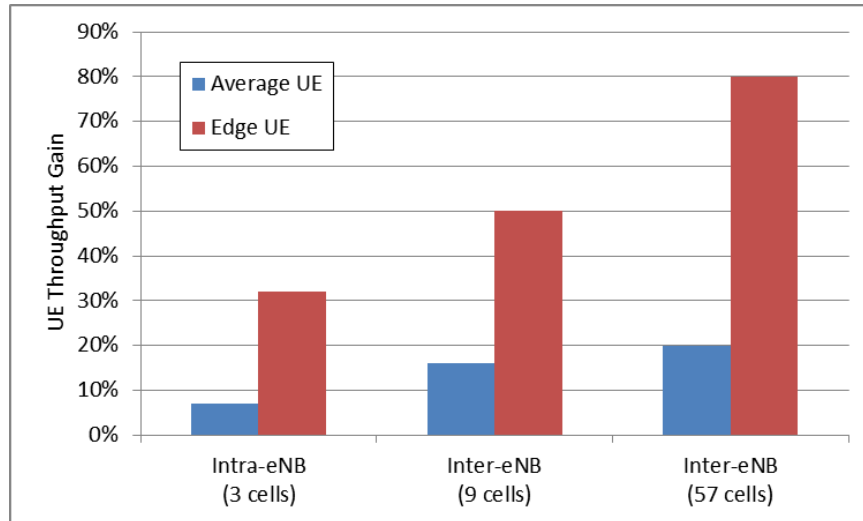

Figure 54. CoMP gain in realistic environment: Combined traffic model (Scenario 2)

Observation:

- With the modified realistic model, the centralized eCoMP could provide more gain compared to that of 3GPP.

A2.4 Evaluation of the autonomous muting with different backhaul latency

// Contributor: NSN

Under the assumption of non-ideal backhaul, latency applies to all messages exchanged. E.g. when the coordinating eNBs are sending CSI and UE average throughput information to the centralized scheduler. Thus the muting decision is based on delayed information from all eNBs as shown in Figure 55 (left). In contrast, every eNB is a decision maker in a distributed architecture thus it can always utilize instantaneous information (benefit metric and penalty of muting derived from instant CSI) from its own cells and delayed information from other eNBs, as illustrated in Figure 55 (right). With fresh information, more frequency selective gain can be obtained when deciding muting pattern since the decision tracks the channel variation more accurately.

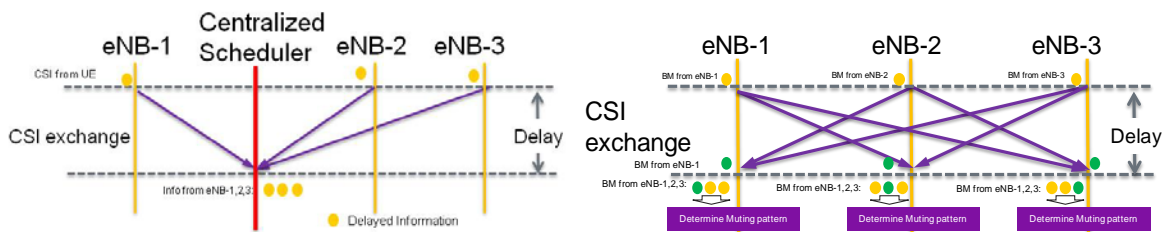

Figure 55. Information exchange in centralized (left) and distributed (right) architecture

As a consequence of using fresh own cell information, the input information to make muting decision at each eNB is different in distributed architecture. As shown in Figure 56 (right), the information available at eNB-1 includes fresh information from eNB1 and delayed information from eNB-2 and eNB-3. Meanwhile, eNB2 has fresh information from eNB2 and outdated information from eNB1 and 3. That means the available information is different for different eNB especially when the backhaul latency is large. One may concern that eNB-1 and eNB-2

may come up with conflicting decisions (e.g. eNB-1 wants eNB-2 to mute, whereas eNB-2 decides not to mute). However, no conflict will happen since each eNB can only decide the muting pattern for cells connecting to itself..

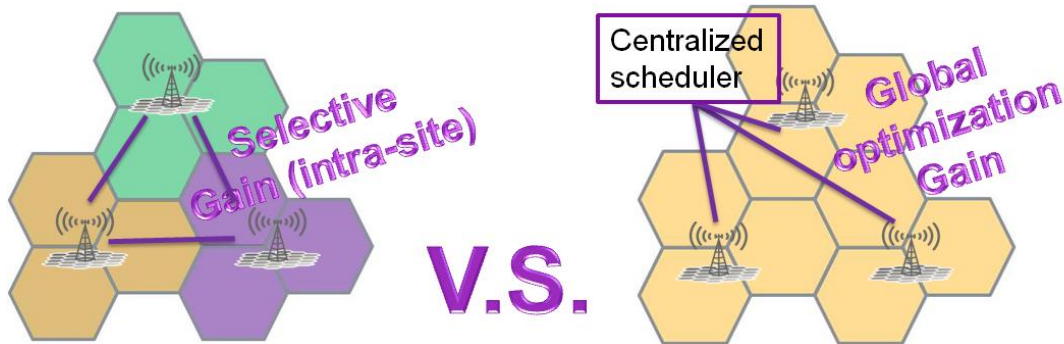

Figure 56. Centralized v.s. Distributed

In summary, distributed architecture can fully utilize locally available fresh CQI information at each eNB resulting high frequency-selective scheduling gains (better fit to the channel), while the centralized approach jointly processes all delayed information resulting in global optimization gain, as illustrated by Figure 56.

The Figure 57 shows coordinated muting performance under different latency assumptions in the most preferable eCoMP scenarios: (9 cells and 9.6Mbps offered load). All simulation assumptions follow TR36.874. Clearly, coordinated muting with centralized architecture is much more sensitive to the backhaul latency than the distributed approach. This is due to using outdated information from all eNBs to make muting decision in centralized scheduler while distributed muting always utilize instantaneous information from its own eNB for muting decision. When extremely large backhaul latency applies, the performance of inter-site distributed muting goes down slowly and gradually approaching that of intra-site coordinated muting which only uses fresh local CSI (neighbor CSI is of no value in extreme large backhaul latency). Even with a modest backhaul latency assumption of 5ms, distributed architecture performs better than the centralized one.

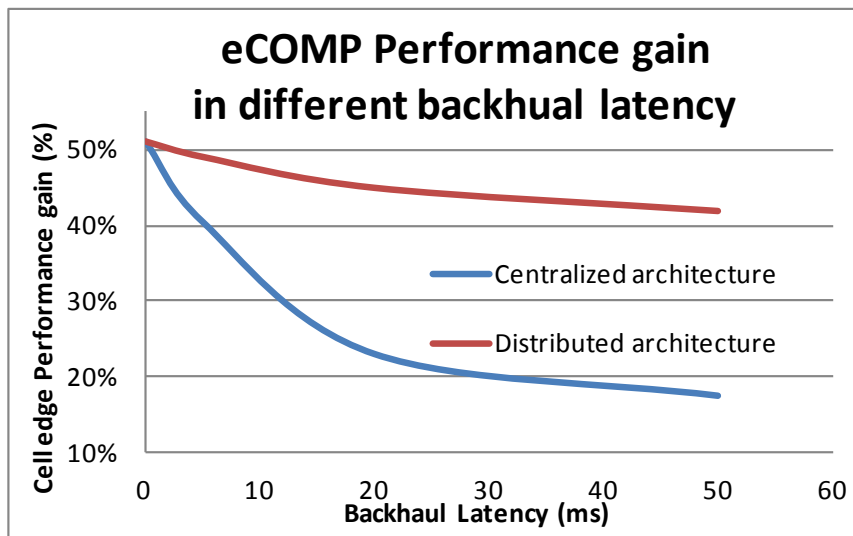

Figure 57. Performance comparison of centralized and distributed architecture under different backhaul latency

Observation



- The performance of eCoMP is sensitive to the backhaul latency. It's observed that the distributed architecture is more robust to the latency than the centralized architecture.



GLOSSARY OF DEFINITIONS AND TERMS

BM	Benefit Metric
CB	Coordinated Beamforming
CoMP	Coordinated Multipoint Processing
C-RAN	Centralized/Collaborative/Cloud/Clean Radio Access Network
CS	Coordinated Scheduling
CSI	Channel State Information
DL	Downlink
Hetnet	Heterogeneous network
ICI	Inter-Cell Interference
JT	Joint Transmission
JR	Joint Reception
LTE	Long term evolution
UL	Uplink
3GPP	3rd generation partnership project

REFERENCES

- [1] 3GPP TR 36.819, Coordinated Multi-Point Operation for LTE Physical Layer Aspects (Release 11), V2.0.0, Sept. 2011.
- [2] Akyildiz Ian F., Gutierrez-Estevez David M., Chavarria Reyes Elias, "The evolution to 4G cellular systems: LTE-Advanced", Physical Communications 3 (2010).
- [3] 3GPP R1-131027, Resource coordination for small cells with non-ideal backhaul, Samsung., Apr. 2013
- [4] 3GPP TS 36.300 , E-UTRA and E-UTRAN Overall description Stage 2 (Release 11), V11.6.0, July 2013.
- [5] P. Sehier, "Coordinated Multi-Point Operation for LTE (CoMP) Techniques, architectures and performance", NGMN F2F Meeting, Seoul, March.22, 2013
- [6] M. Grieger, P. Marsch, and G. Fettweis, "Large Scale Field Trial Results on Uplink CoMP with Multi Antenna Base Stations", IEEE Vehicular Technology Conference, VTC '11-Fall, San Francisco, USA, 2011.
- [7] H. Schoeneich, I. Berberana, M. Grieger, R. Visoz, "Interference Control in LTE-Advanced: An ARTIST4G Overview," Future Network Mobile Summit '12, Berlin, Germany, 2012.
- [8] M. Danneberg, J. Holfeld, M. Grieger and G. Fettweis, "Field Trial Evaluation of UE Specific Antenna Downtilt in an LTE Downlink," ITG Workshop on Smart Antennas (WSA' 12), 2012.
- [9] J. Holfeld, E. Fischer, and G. Fettweis, "Field Trial Results for CoMP Downlink Transmissions in Cellular Systems," International ITG Workshop on Smart Antennas (WSA '11), 2011.
- [10] J. Holfel, I. Riedel, and G. Fettweis, "A CoMP Downlink Transmission System Verified By Cellular Field Trials," 19th European Signal Processing Conference (EUSIPCO 2011), 2011.
- [11] Jaroslav Holiš, Josef Kotalík, Petr Lédl, "Samsung Smart LTE D-RAN Trial in DTAG Network," NGMN F2F Meeting, Seoul, Mar. 22, 2013.
- [12] 3GPP TR 36.874, CoMP for LTE with non-ideal backhaul, v12.0.0, Dec. 2013.