



A Deliverable by the NGMN Alliance

NGMN Use Cases related to Self Organising Network, Overall Description

next generation mobile networks



A Deliverable by
the NGMN Alliance

**Next Generation Mobile Networks
Use Cases related to
Self Organising Network, Overall Description**

Release Date: May 31st, 2007



Document Information

Editor in Charge	Frank Lehser (T-Mobile)
Editing Team	NGMN Technical Working Group "Self Organising Networks", Project 12"
Document status:	Approved
Version:	2.02
Date:	December 5 th , 2008

Abstract

The document reflects a common understanding of the NGMN operators concerning self organizing functionality. It is seen as basis for discussion with vendors to identify solutions improving the operational efficiency of the next generation network. A definition of terms and categorization is given and some high level descriptions of use/problem cases to illustrate necessity of self organizing functionality.

Vendors are expected to deliver feasibility studies to be discussed by NGMN project group with the aim to derive requirements on self organizing functionality for the next generation network.



CONTENT

1	INTRODUCTION.....	4
1.1	SCOPE OF DOCUMENT	5
1.2	NAMING CONVENTIONS AND DEFINITIONS.....	5
1.3	ASSUMED 3GPP NETWORK ARCHITECTURE	7
2	OPERATOR USE CASES	7
2.1	PLANNING.....	9
2.2	DEPLOYMENT	10
2.3	OPTIMISATION	11
2.4	MAINTENANCE.....	14
3	ANNEX.....	16
4	ABBREVIATIONS	16
5	REFERENCES.....	17

1 INTRODUCTION

Reduction of cost and complexity is a key driver for RAN Long Term Evolution. It is therefore of vital interest of operators to minimise operational effort & cost by introducing self-configuring and self-optimising mechanisms. These automated functions aim towards a self-organising behaviour of network increasing network performance and quality by reacting on dynamic variation processes in network. The technical progress in form of higher processing power and better cost efficiency shall be used not only to increase basic end user performance of the new network but also to improve operability.

The early GSM phase was characterized by very local maintenance activities, whereas the current deployed networks are mainly managed by centralized remote operations and maintenance (O&M) applications with all processes in O&M, e.g., planning, measurements, optimization or ordering, are supported by computer aided tools. The next step in automation is a combination of these different functions to ensure an automatic or even autonomous O&M.

The main drivers for automating processes in a mobile network operation are as following:

- The high complexity and the large quantity of parameters in current networks to achieve optimal performance require much effort in the optimisation processes (e.g., O&M functionality, drive tests and interface trace analysis).
- When introducing LTE, it is expected that in many regions at least three mobile networks technologies will be operated in parallel (2G, 3G and LTE/SAE) for some time. It is necessary that nevertheless no additional operational cost is incurred.
- In the NGMN white paper the home zone eNodeB is a clear requirement for indoor deployment to bring fixed-mobile convergence into reality. Such 'Home eNB' are characterized by freedom of location, user group restriction, as well as by very high quantity of new nodes and node manufacturers to be managed.

Especially in the early deployment phase of a new system, the efforts to setup and optimise are significant and traditionally lead to lengthy periods of instability before an optimised and stable network is achieved. It is therefore essential to have the necessary self-organising mechanisms available before commencing the deployment of a new system.

1.1 SCOPE OF DOCUMENT

The scope of the document is to describe operational use cases, where automatic or autonomous procedures are expected to be introduced. The document gives the motivation and an overview of the use cases and examples.

It is recommended that suppliers analyze feasibility of the listed use cases, and work out appropriate self-organizing solutions to reduce operational effort and improve network performance. In addition, it is asked that the necessary measurements, procedures and open interfaces to support self-organising functions in a complex multi vendor environment are addressed during the standardisation of the new systems.

1.2 NAMING CONVENTIONS AND DEFINITIONS

- **Self-organising Functionality**

A self-organising function in a mobile network includes processes which require minimum manual intervention.

In this document self-organizing processes for mobile network operator take place in different functional areas of RAN and Core Network. There are no real hard borders between the functional areas. (For example, parameter optimization can also be seen as part of maintenance.)

- **Planning**

Network planning is the process of preparing the parameters and settings of a network node (including site locations and HW configuration) which need to be prepared by an operator.

It does not include site acquisition and preparation.

- **Deployment**

Deployment includes preparation, installation, authentication and delivering of a status report of a new Network Equipment (NE). It includes all procedures to bring a new node into commercial operation.

- **Self-configuration**

The self-configuration process is defined as the process where newly deployed nodes are configured by automatic installation procedures with the necessary basic configuration for system operation.

This process is performed in the pre-operational state. The pre-operational state is defined as the state where the RF interface is not commercially active.

- **Optimization (self-optimization)**

The (self-) optimization process is defined as the process where UE & eNB measurements and performance measurements are used to (auto-) tune the network.

This process is performed in the operational state. The operational state is defined as the state where the RF interface is commercially active (i.e., cell not barred/reserved).

- **Maintenance**

The maintenance process is defined as the procedures to perform the routine actions which keep the network in working order or prevent trouble from arising. This includes a continuous technological development of the network and also includes the necessary software and hardware upgrades / replacements.

- **eNB Types**

Macro-eNB is used as a synonym for any eNB deployed and maintained by the operator based on its own requirements.

Home eNB is best described as a Pico eNB which is installed by the end-user and cannot be considered as having a fixed location within a PLMN. The Home eNB possibly only requires a subset of the O&M functionality required for the Macro-eNBs. The Home eNB maybe deployed on the same frequency layer as the macro cell, as well as a different layer, and may also be restricted to only a closed user group.

- **Autonomous / Automatic activity**

An autonomous activity is a process which is fully controlled by a machine without requiring human interaction.

An automatic activity is a process where a significant part of the action is handled by a machine but some human interaction is required (e.g., where an operator is required to activate machine specific macros, or required to verify results).

- **Plug and Play**

Plug and Play (PnP) as a feature in a mobile operator's network allows the addition of new NEs or NE components (e.g., HW boards) without requiring manual configuration or manual installation of supporting software.

1.3 ASSUMED 3GPP NETWORK ARCHITECTURE

The following 3GPP Network Architecture will be assumed in this document:

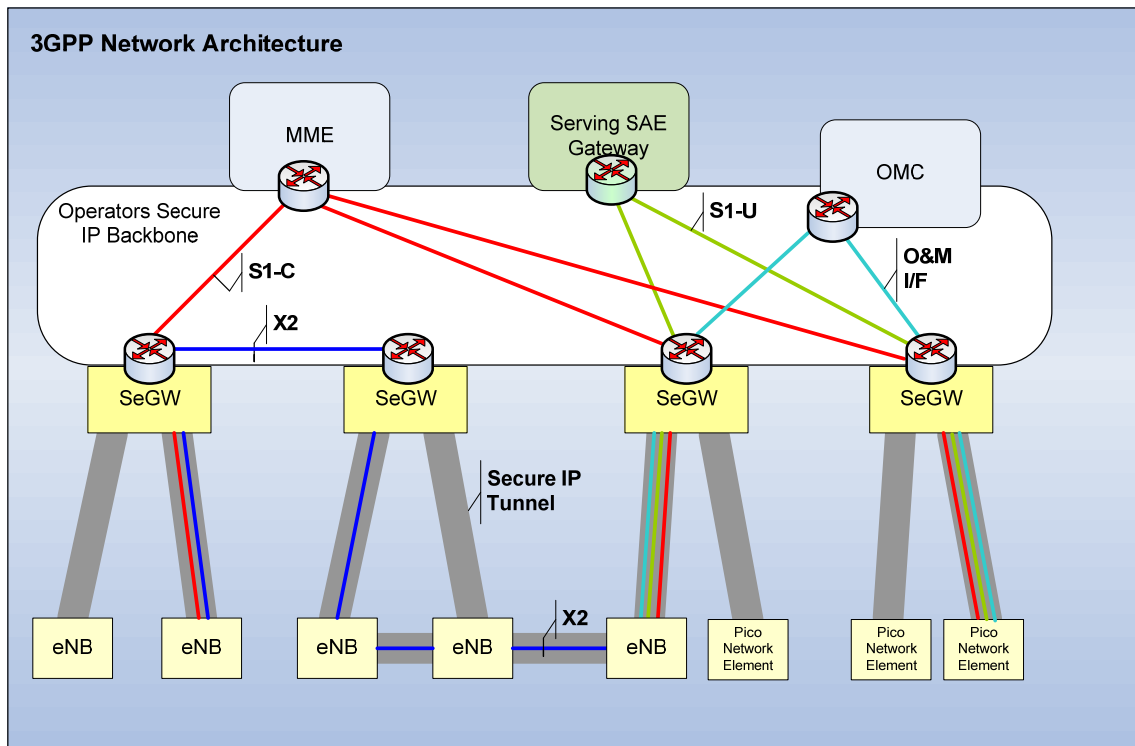

Figure 1: Assumed Network Architecture

2 OPERATOR USE CASES

The operator use cases are categorised into following groups:

- Planning
- Deployment
- Optimization
- Maintenance

The objective of the document is to provide generic use cases covering all NEs, however as expected some use case are strongly linked with the handling of RAN nodes, especially with the eNBs.

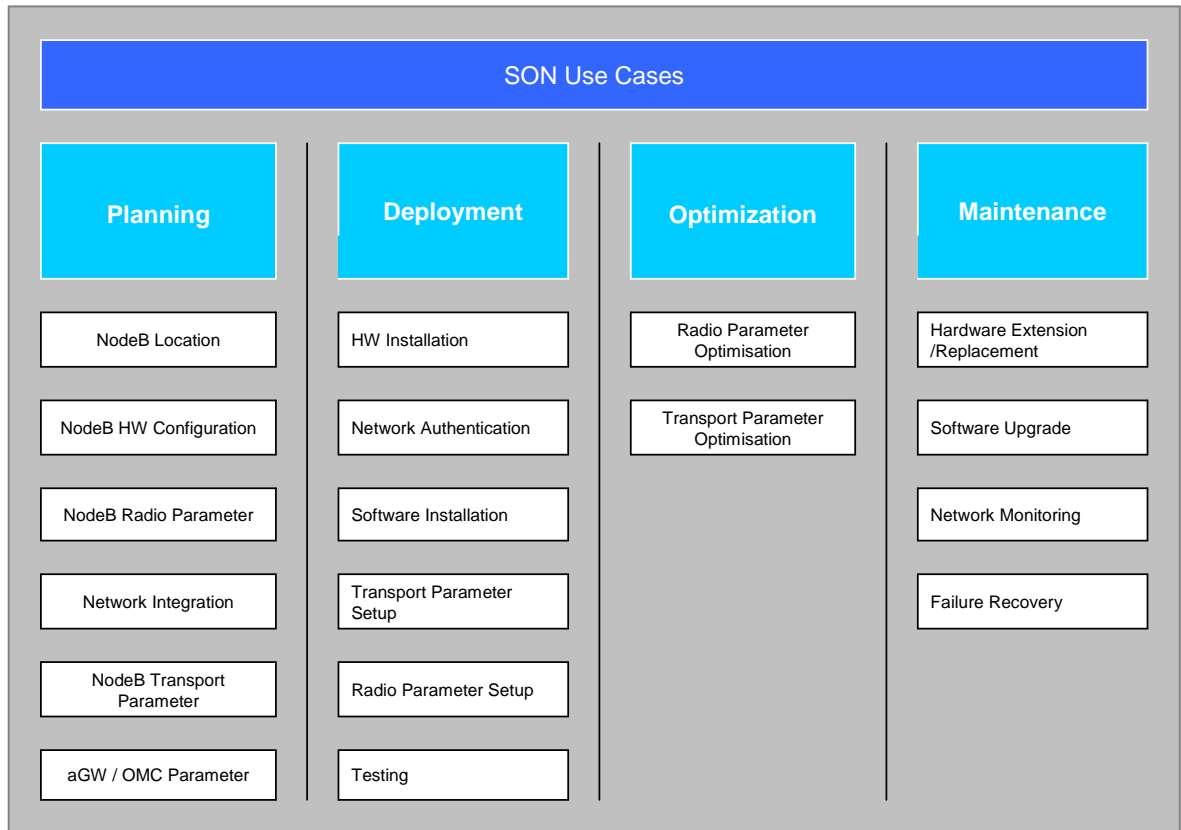

Figure 2: Categories and sub-groups of SON related use cases

The planning, deployment, optimization and maintenance categories do not have to be split into a timeline, however for simplicity are described here as subsequent operations.

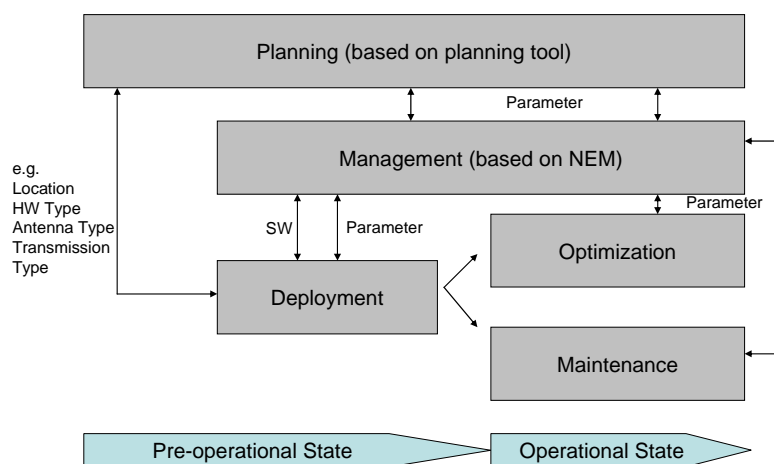

Figure 3: Planning, installation and configuration process

2.1 PLANNING

As mentioned in sub-clause 1.2.2, planning includes preparing the necessary parameters and settings that are needed before deploying a new eNB. After planning all necessary parameters and settings, the new eNB can be placed and attached to the network. The necessary planning would be reduced by the extent covered by self-configuration and self-optimisation.

The planning of a new eNB can be divided into the following steps:

- Planning of location (based on coverage/capacity goals)
- Planning of HW configuration
- Planning of radio parameters
- Planning of transport parameters
- Planning of network integration (defining aGW/O&M/neighbour nodes)
- Procurement of the eNB

The different procedures behind the single steps may vary in an operator specific way.

The following use cases give practical examples for the functional split. It is not a complete list of possible use cases and may not be applicable to all operators. Nevertheless they shall give some guidance what is meant with the described self organising functionality. In a realistic self-organizing solution some of the listed uses cases may be substituted by self-X (self-configuration, self-optimisation) functionality.

Use Case Examples	Short description
Planning location of a new eNodeB	Planning of location based on coverage and capacity goals, HW type and antenna type
Planning of radio parameters of a new eNodeB	Planning of power settings, neighbourhood list, and handover settings. Goal: to be substituted by self-configuration and self-optimisation.
Planning of transport parameter of a new eNodeB	Planning of transport parameters like addresses, Transport QoS settings etc. Goal: to be substituted by self-configuration and self-optimisation
Planning data alignment for all neighbour nodes	Including neighbourhood list retrieval of neighbour nodes and announcement of the new node to all neighbouring nodes including data base retrieval Goal: to be substituted by self-configuration and self-optimisation
Planning of a new Home eNB	Due to unclear concept of Home eNB the consequences of Home eNB on planning is ffs.

2.2 DEPLOYMENT

The deployment of a new eNB is to install the eNB hardware to the designated site, and to setup the necessary configurations preceding commercial operation. Although this would be mainly a manual process, effort can be reduced by having a self-configuring functionality in the new eNB. This may entail relevant updates also in the neighbour eNBs as well as associated aGWs.

Deployment use cases can be categorized with the help of this life cycle:

- Hardware installation
- eNB/network authentication
- Software installation
- Transport parameter setup
- Radio parameter setup
- Testing

After the physical installation of the hardware and cabling for antennas and networking, the new eNB needs to discover the NEM and it needs to be authenticated to access the NEM. After the eNB has been successfully authenticated, it can perform further self-configuration procedure such as downloading of relevant parameters and software, as well as transport (S1/X2) setup. There may be some implications also in the neighbouring eNBs as well as associated aGWs, e.g., neighbour cell information and tracking areas need to be configured. The eNB shall further run a self-test procedure with the configured parameters.

The following use cases give practical examples for the functional split. It is not a complete list of possible use cases and may not be applicable to all operators. Nevertheless they shall give some guidance what is meant with the described self organising functionality. In a realistic self-organizing solution some of the listed uses cases may be substituted by self-X (self-configuration, self-optimisation) functionality.

Use Case Examples	Short description
HW Installation	Site preparation and HW installation, includes also error free cabling including PnP behaviour for all components (Antenna, Line, Boards, Cages)
Node authentication	Mutual authentication process of the node
SW Installation	Retrieval of the configuration data from the planning data and default data base
Self test	Self test of the Hardware, including feeder loss test, radio performance test and site acceptance test, including a site acceptance report send to the OMC

2.3 OPTIMISATION

Mobile networks are dynamic structures, where continuously new sites are deployed, capacity extensions are made and parameters are adapted to local conditions. The optimisation process to achieve superior performance can be described by the following figure:

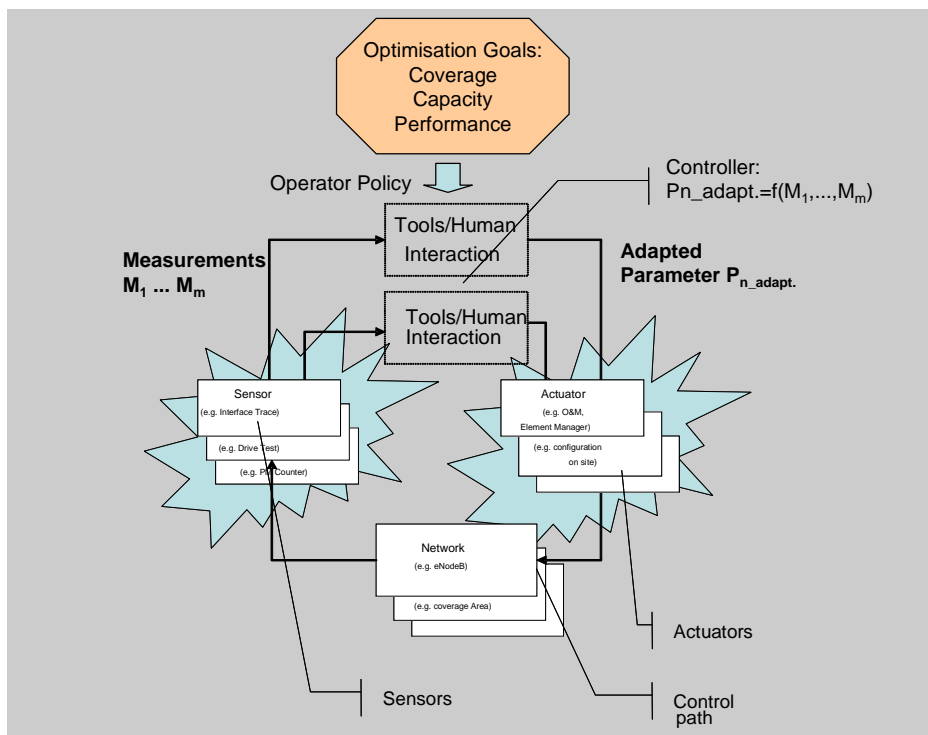

Figure 4: Closed loop optimization process today

Network optimization is a closed loop process of parameter deployment, performance evaluation, parameter optimisation, and redeployment of optimized parameters to the network. The controlling function can be accessed by human operators or by automatic processes of machines.

Input data for the optimization process shall be gathered by various techniques and from various sources like O&M performance measurements, O&M alarm measurements, and measurements based on interface traces (Uu, lub, lu), as well as drive tests combining air interface measurements with location information. These measurement results can be used in an algorithm to derive the optimum parameters. The optimisation function should aim at optimising parameters to meet a certain goal, be it coverage, capacity, or performance. The algorithm for optimisation would be operator specific and would be an implementation issue. However, the necessary measurement functions and interfaces need to be defined in the standards.

Considering equipment of different vendors the situation gets even worse, as different vendors may support different performance counters and measurements in their O&M systems. Network operators in a multi-vendor environment had to develop adaptation layers to translate the performance measurements from different vendors such that a common optimization platform can be used.

The optimisation related use cases can be split as follows:

- **Radio parameter optimisation**
This is to optimise radio related parameters to achieve the best performance. Non exhaustive list of parameters to be adjusted includes Tx power, antenna tilting, neighbour cell information, handover parameters, other RRC/MAC/PHY parameters, and potentially also some NAS parameters like tracking areas. Effectiveness and feasibility of automatic optimisation of these parameters shall be studied.
- **Transport parameter optimisation**
This is to optimise transport parameters, e.g., S1/X2 associations, routing, and PHBs, such that the transport network resources are efficiently utilised. It can be seen that this optimisation is to minimise the transport network costs. Effectiveness and feasibility of automatic optimisation of these parameters shall be studied.

The optimisation algorithm would depend on the operator policy, and would be an implementation issue. It is however essential to identify all the necessary “hooks” to realise self-optimisation, such as UE/eNB measurements and interfaces, and to standardise the necessary “hooks,” especially to cope with multi-vendor scenarios.

The optimisation process can be capacity driven, coverage driven, or performance driven.

- **Coverage** driven optimisation means that parameters are changed to increase cell coverage
- **Capacity** driven optimisation means that parameters are changed to increase the network or cell capacity
- **Performance** driven optimisation means that parameters are changed to increase user performance e.g. the throughput per user, user plane latency.

Since these three are mutually related, in order to optimise towards one dimension (capacity, coverage, or performance), requirements for the other two shall be input as constraints in the optimisation process. For example, capacity driven optimisation would be to optimise parameters such that the capacity (e.g., in terms of number of supportable UEs or cell throughput) is maximised, given the required coverage and performance (e.g., QoS and service sustainability). It must be emphasized that every optimisation is a trade-off between the optimisation goals coverage, capacity and performance (or quality).

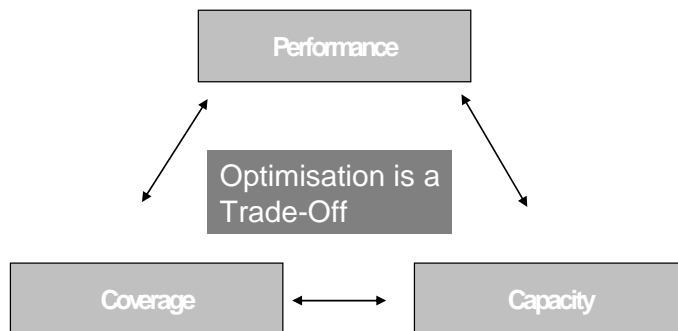

Figure 5: Goals of the optimization related use cases.

The following use cases give practical examples for the functional split. It is not a complete list of possible use cases and may not be applicable to all operators. Nevertheless they shall give some guidance what is meant with the described self organising functionality. In a realistic self-organizing solution some of the listed uses cases may be substituted by self-X (self-configuration, self-optimisation) functionality.

Use Case Examples	Short description
Radio Parameter Optimisation	
Neighbour Cell List Optimisation	Optimisation of existing neighbour cell list of a cell with all relevant neighbours and the associated parameterisation in the neighboured cell.
Interference Control	Optimize power and scheduling of sub-tone in downlink with minimal operational effort.
Handover Parameter Optimisation	Optimize handover parameter with minimal operational effort (related to neighbour cell list optimisation)
QoS related parameter Optimisation	Optimise RRM parameter impacting QoS with minimal operational effort
Radio Parameter related Optimization Scenarios with Home eNB	Due to unclear concept of Home eNB the consequences of Home eNB on optimisation is ffs.
Transport Parameter Optimisation	
Transport Parameter Optimisation	Optimize transport parameter with minimal operational effort
Routing Optimisation	Optimisation of data routing in a meshed network
Transport Parameter related Optimization Scenarios with Home eNB	Due to unclear concept of Home eNB the consequences of Home eNB on optimisation is ffs.

2.4 MAINTENANCE

The aim is to allow a smarter operation and maintenance in LTE compared to the situation as it is today. Many of the use cases are based on direct inputs from operations and planning departments. As a consequence these use cases are more related to daily operations and the most annoying problems there. Although some use cases may not be solved with self-organizing functionality, they are seen to have a high potential in reducing operational effort and saving operational costs.

The use cases can be categorized into the areas:

1. **Hardware Extension /Replacement**

Any upgrade, extension or replacement of hardware should require minimal operator attention. Hardware shall allow plug 'n play behaviour. Technicians shall be able to handle hardware from different suppliers without special training.

2. **Software Upgrade**

Software update shall need minimum operator attention. Any functional outage (incl. loss of surveillance) must be minimized.

3. **Network Monitoring**

The system should provide sufficient measurements and analyses of RAN performance for planning further improvements. Multi-vendor scenarios should be supported without any extra stress. Tracing shall be supported for trouble shooting and for special tasks (e.g., UE analysis).

4. **Failure Recovery**

Recovery of NW element failures should not require complex manipulation by an expert.

The following use cases give practical examples for the functional split. It is not a complete list of possible use cases and may not be applicable to all operators. Nevertheless they shall give some guidance what is meant with the described self organising functionality. In a realistic self-organizing solution some of the listed uses cases may be substituted by self-X (self-configuration, self-optimisation) functionality.

Use Case Examples	Short Description
Hardware Extension /Replacement	
Hardware/ Capacity extension	PnP Hardware extension / replacement with minimum NE outage
Automatic Inventory	PnP Hardware Inventory
Software Upgrade	
Automatic SW Download to eNodeB	Reliable automatic software management
Automated NEM upgrade	PnP NEM Upgrade
Network Monitoring	
Cell/Service outage detection	No more sleeping cells for any service without alarm
Automatic PM data Consolidation	PM data analysis and KPI reporting on eNB
Performance Management in real time via Itf N	Fast analysis of Network problems / changes
Information correlation for fault management	Unambiguous Alarm detection
Subscriber and equipment trace	Implement trace functionality e.g. for specific subscribers or cells
Failure Recovery	
Cell outage compensation	Automatic reaction on detected sleeping cell
Compensation for Outage of higher level network elements	Outage of higher level network elements (e.g. NEM) shall be compensated by other elements of this network level
Fast recovery on instable NEM system	High Availability / fast Recovery of NEM
Mitigation of outage of units	Hot Standby functionality, compensation by using redundancy

3 ANNEX

Detailed descriptions of example use cases can be found in “An Annex Deliverable by the NGMN Alliance - NGMN Informative List of SON Use Cases”

4 ABBREVIATIONS

CM	Configuration Management
CN	Core Network
FM	Fault Management
IM	Inventory Management
Itf. N.	Northbound Interface
KPI	Key Performance Indicator
LTE	Long Term Evolution
MIB	Management Information Base
NE	Network Element
NEM	Network Element Manager
O&M	Operation and Maintenance
OS	Operating System
OSS	Operations Support System
PI	Performance Indicator
PM	Performance Management
RAN	Radio Access Network
SAE	System Architecture Evolution
SMA	Software Management Application

5 REFERENCES

- R2-061545, Complexity minimisation to setup and optimise an LTE network, T-Mobile, KPN
- R2-061929, Standardisation policy for plug and play RAN, NTT DoCoMo
- R2-062230, Discussion on Auto-configuration and Dynamic Optimization, Lucent, T-Mobile
- R2-062156, Measurements for Network Optimization, Motorola, T-Mobile
- R2-062411, Support for self-configuration and self-optimisation Proposal for Stage2 (Chapter 19.1),
- R2-062940, Support for self-configuration and self-optimisation Proposal for Stage2 (only RAN2 relevant part), T-Mobile
- R3-061487, Self-Configuration and Self-Optimisation, Problem Statement and Definition, T-Mobile
- R3-061488, Impact of Self-configuration and self-optimisation functionality on architecture & interfaces, T-Mobile
- R3-061487, Self-Configuration and Self-Optimisation, Problem Statement and Definition, T-Mobile & KPN
- R3-061509, Clarification of functions for self-optimization and self-configuration, NTT DoCoMo
- R3-061559, Usage of Self Tuning Protocols, Nortel
- R3-061482, Self-configuration and self-optimization in E-UTRAN, Lucent
- R3-061530, Self optimisation Scenarios, NEC
- S2-063879, Support for self-configuration, T-Mobile
- R3-061715 Discussion of some solutions to Self-Configuration, Huawei
- R3-061758 Self configuration and self optimisation for neighbour cell lists, Nokia
- R3-061748 Consideration on Neighbours Self-Optimization LTE, Nortel
- R3-061749 Consideration on Coverage-Capacity Self-Optimization LTE, Nortel
- R3-061850 Self configuration & self optimization use cases, T-Mobile, KPN
- R3-061974 Self configuration & self optimization use cases, T-Mobile, Nokia